

# SCREWLine<sup>3</sup> FREE-COOLING

FREE-COOLING high efficiency air cooled liquid chiller for outdoor installation

## WDAT-SL3 FC 200.2 - 580.2 RANGE

Nominal cooling capacity from 464 kW to 1375 kW



- ▶ FREE-COOLING mixing section on source exchanger
- ▶ R-134a double screw compressors
- ▶ Two independent refrigeration circuits
- ▶ Chilled water down to -8°C
- ▶ Partial recovery of the condensing heat
- ▶ Diffusers for thermodynamic recovery fans

## EXCELLENCE version

- ▶ Up to 45°C outdoor air temperature / Perfect for LEED



# Clivet hydronic system

Designed to provide high energy efficiency and sustainability of the investment, the wide range of Clivet liquid chillers and heat pumps for high efficiency air conditioning of Residential and Commercial spaces and for Industrial applications it is available with air or water source.

## HYDRONIC System - Air Source

	Small and Medium Commercial			Large Commercial and Industry		
	ELFOEnergy Extended Inverter ELFOEnergy Edge ELFOEnergy Duct Inverter	ELFOEnergy Medium / Large <sup>3</sup> ELFOEnergy Vulcan Medium ELFOEnergy Duct Medium	ELFOEnergy Magnum	Remotex Multi Scroll Technology	SPINchiller <sup>2</sup> / SPINchiller <sup>2</sup> Duct Multi Scroll Technology	SCREWLine <sup>3</sup>
Capacity (A35/W7)	4 ÷ 50 kW	20 ÷ 216 kW	50 ÷ 375 kW	237 ÷ 2050 kW	115 ÷ 1350 kW	467 ÷ 1523 kW
ErP compliance (Heat pumps only)	ErP A	ErP A	ErP A	ErP A	ErP A	-
Products						
Chillers	WSAT-XIN iDC Inverter EXC A PRM D	WSAT-XEE EXC A PRM C	WSAT-XIN iDC Inverter EXC A WSAT-XEM EXC A PRM C	MSRT-XSC3 EXC A PRM B	WSAT-XSC3 SUP A EXC A PRM C	WDAT-SL3 EXC A WDAT-IL3 EXC A
High Temperature Chillers, External Air			WSAT-XEM EXC A	MSRT-XSC3 EXC A	WSAT-XSC3 SUP A EXC A	WDAT-SL3 EXC A
Free Cooling Chillers		WSAT-XEE (FC) A C	WSAT-XEM FC EXC A		WSAT-XSC3 FC EXC A	WDAT-SL3 FC EXC A
Heat pumps	WSAN-XIN iDC Inverter EXC A PRM B WSAN-XMI iDC Inverter EXC A	WSAN-XEE A B	WSAN-XIN iDC Inverter EXC A WSAN-XEM EXC A	MSRN-XSC3 EXC A PRM B	WSAN-XSC3 EXC A	
High temperature water Heat pumps		WBAN A	WSAN-XEM HW EXC A			
Multi-function Heat pumps			WSAN-XIN MF iDC Inverter EXC A WSAN-XEM MF EXC A		WSAN-XSC3 MF EXC A	
Ducted units	WSA-XIN (Chiller) EXC Inverter EXC A WSN-XIN (Heat pump) iDC Inverter EXC A	WSA-XEE (Chiller) A WSN-XEE (Heat pump) A			WSA-XSC2 (Chiller) A	

## Specialization

Every intended use has specific requirements which determine the overall efficiency. For this, the Clivet hydronic system always offers the best solution in every project.

- Modular range with over 8000 kW of overall capacity
- Capacity control with Screw and modular Scroll technology
- Multifunction versions
- Outdoor or indoor (ductable type) installation

### Centrality of the Air Renewal

From the Air Renewal depends the comfort in the spaces. Since it often represents the main building energetic load, it also determines the running costs of the entire system.



**ZEPHIR3**  
Packaged Primary Air supply system with thermodynamic energy recovery.

- Simplifies the system, reduces the heating and cooling generators
- Purifies the air with standard electronic filters
- Increases the energy efficiency and it also allows a savings of 40% on the running costs
- From -40°C to +50°C of outdoor air temperature

### Terminal and AHU complete system

The hydronic terminal units are very diffused for their versatility and reliability. The Clivet range includes many versions that simplify the application in different types of installation and building.



**ELFOspace**  
High energy efficiency hydronic terminal units  
**AQX**  
Air-conditioning unit

- Cased and uncased terminal units, from 1 to 90 kW
- Horizontal and vertical installation
- Energy-saving DC fans
- Modular air conditioning units up to 160.000 m<sup>3</sup>/h
- EUROVENT certification

## SCREWLine<sup>3</sup>: Screw technology for an efficient and versatile product

SCREWLine<sup>3</sup> is the new generation of Clivet liquid chillers with Screw compression technology: high energy efficiency, great operating reliability and maximum choice versatility, with many versions and models for different types of installation.

### WDAT-SL3

#### Air cooled water chiller

- EXCELLENCE high efficiency version
- PREMIUM compact version (Sales available only out of EU)
- Continuous capacity control
- Operating with 52°C of outdoor air temperature
- Total / partial recovery of the condensing heat
- Eurovent certification

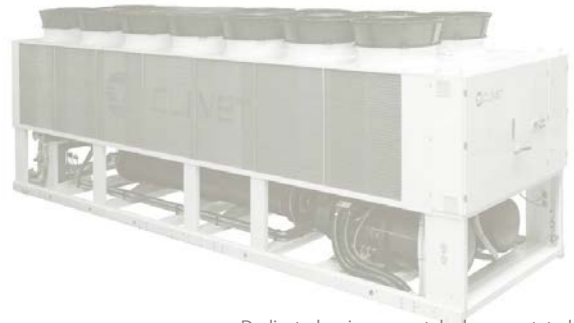

Dedicated series separately documented

### WDAT-SL3 FREE-COOLING

#### Air cooled water chiller with FREE-COOLING

- EXCELLENCE high efficiency version
- Continuous capacity control
- Direct FREE-COOLING
- No-glycol FREE-COOLING



## Precise and economic operating

In air conditioning of buildings and in industrial processes, thermal loads vary over time. The modulating capacity control (stepless) on two refrigeration circuits continually keeps in balance the Clivet unit with the installation, allowing to:

- follow the load also with a great staging
- save supplying only the necessary energy without fluctuations of electric power input
- stabilize the supplied water temperature



## New generation of compressors

The new generation of screw compressors is the result of the continuous evolution for the operating range extension and the overcoming of the traditional efficiency limits at partial load.

New internal geometry, original lubrication system, electronically controlled, innovative capacity modulating control (stepless): they are some of the developments that allow an application versatility and the increase of the seasonal efficiency.

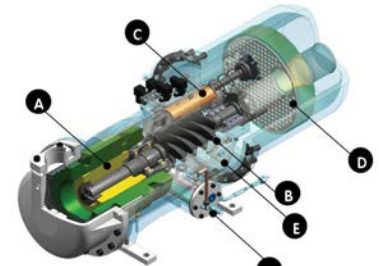

**A** Electric motor  
**B** Twin screw rotor  
**C** Continuous capacity control  
**D** Oil separator  
**E** Economiser door  
**F** Oil level sensor control

## Reliable

The load variability involves the continuous variation of the refrigerant volume moved by compressors. The electronic expansion valve (EEV), standard on Clivet units, adapts rapidly and precisely to the actual load required for usage, allowing stable and reliable control in comparison with mechanical thermostatic valves (TEV). This results also in a further increase in efficiency and longer compressor life. The overheating control allows preventing phenomena that are hazardous to the compressors, such as overtemperature and return fluids, thereby increasing even more efficiency and durability.

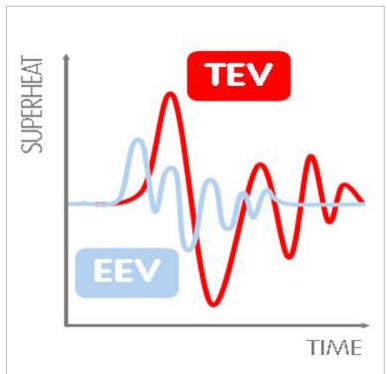

## Efficient and silent ventilation technology

Also the innovative air handling system on the external exchangers is the result of the Clivet design evolution. The new AxiTop diffuser creates an ideal air distribution: it aerodynamically decelerates the flow and transforms a big part of its dynamic energy in static pressure, obtaining:

- -3 dB of sound reduction
- reduction of 3% of the absorbed energy

Moreover all units are supplied with a condensation electronic control. It automatically reduces the fan speed as the heat load drops.

Since fans are the unit's main noise source, the benefits are evident especially during the night hours, when the load is reduced but sensitivity to noise is enhanced.

All this translates into a reduction of sound pressure down to 8 dB(A) compared to full load operation in 90% of operating time of the unit.

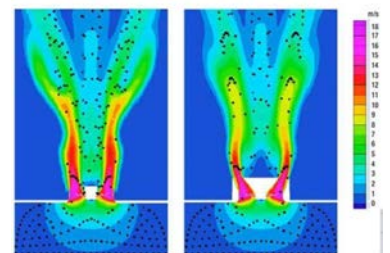

No Axitop      Axitop  
Energy efficiency improved by Axitop

## Advanced integrated pumping system

Searching the maximum overall efficiency, also the energy used for the heat transfer fluid pumping has its importance. HYDROPACK technology developed by Clivet reduces consumptions and offers an exceptional functional reliability at the same time.

HYDROPACK uses groups of two or three pumps in parallel. It automatically reduces the water flow-rate under critical conditions, avoiding blocks for overload and consequent interventions of specialized technical personnel. It is very useful during start-ups, at restart after operating breaks or after a long period of inactivity.

Thanks to its modularity, HYDROPACK keeps a good water circulation in the installation also if one pump is temporary unavailable. With a deactivated pump, the residual flow-rate is in fact:

- about 80% of the nominal flow-rate (HYDROPACK with 3 pumps)
- about 60% of the nominal flow-rate (HYDROPACK with 2 pumps)

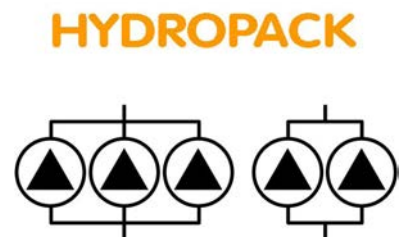

## Perfect for LEED certification

The whole EXCELLENCE range satisfies both requirements 2 (Minimum Energy Performance) and 3 (Fundamental Refrigerant Management) of Energy and Atmosphere section. They also meet Credit 4 parameters (Enhanced Refrigerant Management) allowing 2 points acquisition.

Clivet is committed in promoting the green building principles and has become a member of GBC Italia. This organization collaborates with USGBC, the U.S. nonprofit organization that promotes worldwide the LEED system of independent certification.



## The advantages of the modular solution

In the event of particularly large buildings requiring high capacities, it is advisable to use several units. The ECOSHARE technology developed by Clivet allows to coordinate up to 7 units in local network, in parallel with modular logic, with the following advantages:

- greater efficiency, because the compressors are sequentially activated exploiting at most their point of operating with the lowest consumption, and the pumping units are activated only when necessary
- greater flexibility, thanks to capability of the automatic control to follow the load
- increased reliability, since the malfunction of one unit does not compromise the capacity supply of the other units.

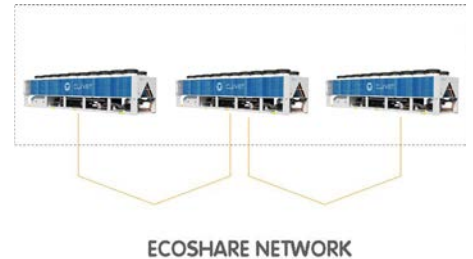

## Remote system management

The unit is standard equipped with:

- potential-free contact for remote on/off control
- potential-free contacts for the compressor status display
- setting from user interface: Off / local On / serial On
- potential-free contact to remote a general alarm

Thanks to the different communication protocols available, the unit is able to exchange information with the main supervisory systems using serial connections.

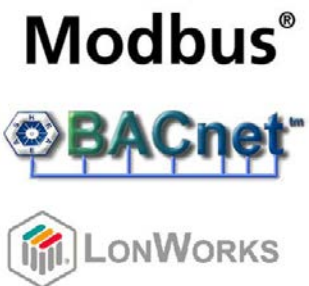

## FREE-COOLING always convenient

For industrial or civil applications where cooling capacity required is stable in any outdoor condition and it is not effected by outdoor temperature, using solutions that exploit low outdoor temperatures for supplying cooling capacity for free is strongly suggested.

The new SCREWLine3 FREE-COOLING series is the answer to that, and thanks to large exchanging surfaces with an antifreeze solution drives to notable annual energy consumption savings, up to 40% in harsh climate.

Not only great winter performances thanks to FREE-COOLING but also all SCREWLine3 benefits and especially very high efficiency at high outdoor temperature conditions.

During one operative year of FREE-COOLING units 70% of the time compressors are running and providing a quite important cooling capacity amount.

It is mandatory to provide a good efficiency even when FREE-COOLING is OFF, in these conditions SCREWLine3 drives to an high saving thanks to a full load efficiency up to 3,1.

Available with two configurations:

- Direct FREE-COOLING (FCD): for systems with glycol.
- Glycol free FREE-COOLING (FCI): for systems without glycol

## 10% of savings with an higher set point

For industrial applications, water supply could be different than 7°C.

With FREE-COOLING units the advantages in terms of efficiency increasing water temperature set-point by few degrees is even more noticeable, driving to annual energy savings higher than 8% with a set point of 10°C for example, concrete economical value for this kind of applications.

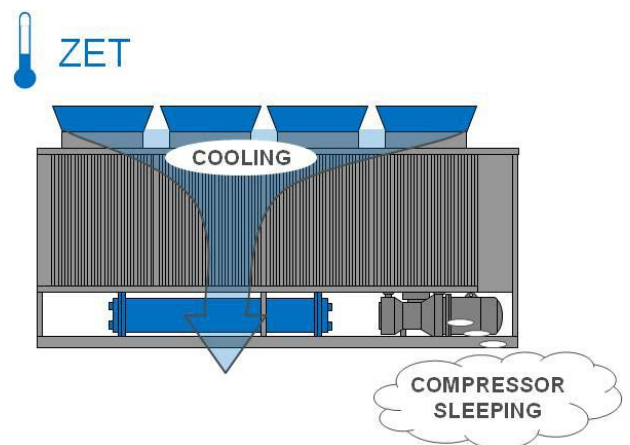

## Further considerations on the installation

The vast operating field of SCREWLine<sup>3</sup> allows it to adapt to most system applications.

In some cases, special duty conditions may exceed the unit operating range.

Simple devices on the system allow proper operation and meeting any requirement.

Here are two examples.

### Water flow-rate values outside the limits

SCREWLine<sup>3</sup> operates with constant water flow-rate to the evaporator, between a minimum and maximum value indicated in the technical documents.

Flow-rate values below the limit may cause unwanted formation of ice, incrustations, reduced control precision, and the unit to stop following the intervention of built-in safety devices.

Flow values above the limit may cause high pressure drops, high pumping costs, and reduced control precision, and erosion damages to the exchangers.

In this example, the required flow-rate is lower than the maximum value allowed to the evaporator, while the operating temperatures fall within the functional field of the unit.

A properly sized bypass piping resolves the problem.

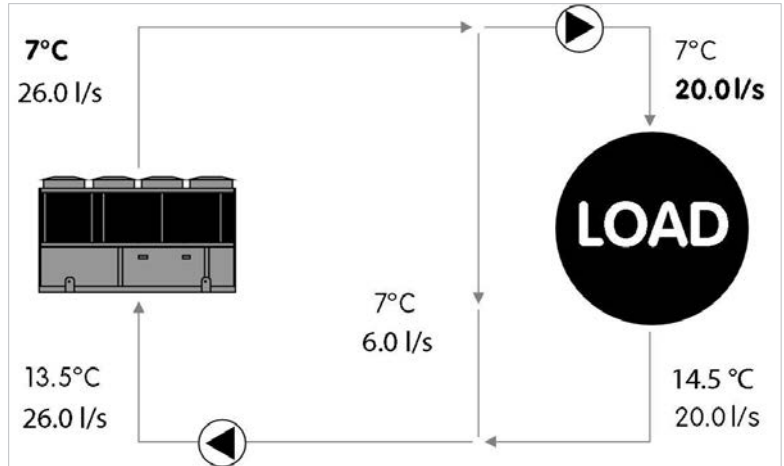

Example referred to WDAT-SL3 FC 280.2 EXCELLENCE version. Appropriate water flow-rate for the correct unit operation.

### Temperature values outside the limits

SCREWLine<sup>3</sup> operates with the system supply temperatures indicated in the technical documentation.

Temperature limits below the limit may cause unwanted formation of ice and the unit to stop following the intervention of built-in safety devices.

Temperature values under the limit may cause malfunctions and damages to the compressors, reduced control precision, and the unit to stop following the intervention of built-in safety devices.

In this example, the required temperature exceeds the maximum value allowed to the evaporator, while the water flow-rate falls within the functional field of the unit.

A properly sized bypass piping and mixing system resolve the problem.

Should both the water flow-rate and the operating temperature exceed the values intended for the chiller, all you have to do is combine the two cases described above.

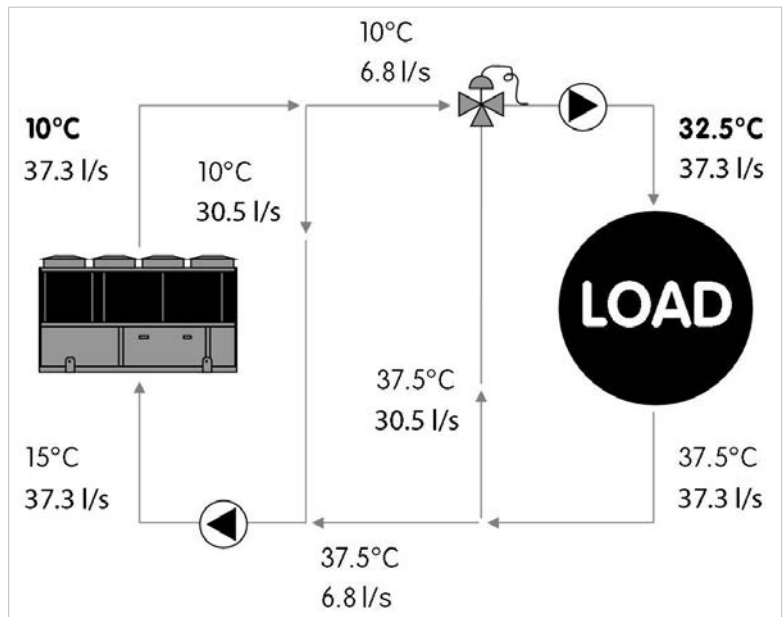

Example referred to WDAT-SL3 FC 280.2 EXCELLENCE version. Appropriate supply water temperature for the correct unit operation. Nominal water flow-rate with water 15°C-10°C

### Evaporator thermal gradient

SCREWLine<sup>3</sup> nominal capacities refer to an evaporator thermal gradient equal to 5 °C. A different thermal gradient may be used in full load operation, provided that both the operating flow and temperatures fall within the limits. As an indication, this corresponds to a minimum thermal gradient of approximately 4 °C and a maximum of 7 °C (the exact values must be determined based on the allowed flows and temperatures).

# Standard unit technical specifications - FCD configuration

## Compressor

Compact semi-hermetic compressor with double helical screw: the main rotor (male, with five lobes) is directly driven by the electric motor, while the secondary rotor (female, with six vanes) is driven by the primary rotor. Continuous modulation of the dispensed cooling capacity, with no-load start-up. Tightness is guaranteed by precisely fitting clearances in the mechanical processing of all moving parts and by a special system of oil circulation between the rotors. Spontaneous-circulation lubrication system through pressure difference, coupled with a high-efficiency separator, level indicator and oil filter (replaceable). Oil heater with electric element for preventing excessive dilution of the refrigerant, automatically inserted in all phases during which the compressor is turned off. Electronically-controlled oil level shown on graphic display. Three-phase asynchronous motor with two poles, cooled by the extracted gas, with star/delta reduced-load start-up. Integrated electronic protection module with discharge temperature safety sensor, maximum temperature sensors for windings, motor rotation sensor and phase monitoring device. Cut-off valve on refrigerant discharge line. Filter on suction line at compressor input point. Integrated silencer and non-return valve on compressor discharge outlet. Automatic safety valve inside compressor between high (HP) and low (LP) pressure areas.

## Structure

Structure and base made entirely of sturdy sheet steel, thickness of 30/10 or 40/10, with the surface treatment in Zinc-Magnesium painted, for the parts in view, with polyester powder RAL 9001 that guarantees excellent mechanical characteristics and high corrosion strength over time.

## Panelling

External pre-painted zinc-magnesium paneling, thickness 10/10, with the surface treatment in Zinc-Magnesium painted with polyester powder RAL 9001 that ensures superior resistance to corrosion for outdoor installation and eliminates the need for periodical painting. The panels can be easily removed to fully access internal components and are lined with sound-proof material on the inside to contain the unit's sound levels.

## Internal exchanger (evaporator)

Direct expansion exchanger with refrigerant side independent circuit for each compressor. The exchanger is composed of a cover made of carbon steel. The Direct expansion exchanger with refrigerant side independent circuit for each compressor. The exchanger is composed of a cover made of carbon steel. The tubes, anchored to the tube plate by mechanical expansion, are made of copper, high efficiency, internally rifled to improve thermal exchange and specially designed for use with modern ecological refrigerants. It also includes a water side protection differential switch, an anti-freeze heating element to protect against icing, and covering in closed-cell thermo-insulating material that prevents the formation of condensation and heat exchange with the exterior. The water connections of the exchanger are quick-release with splined joint.

## External exchanger (condenser)

Finned exchanger, made from copper pipes arranged in staggered rows and mechanically expanded for better adherence to the collar of the fins. The exchangers are planned, designed and produced directly by CLIVET. The fins are made of aluminium with a special corrugated surface, set a suitable distance apart to ensure maximum heat exchange efficiency. A proper liquid supply of the expansion valve is ensured by the subcooling circuit. Each finned heat exchanger is directly cooled by the air flow of its specific fans.

## Fan

Axial fans with high performance and low-noise, balanced statically and dynamically, with blades in aluminum sheet coated in PP and sickle profile terminating with "Winglets"; Wall ring in sheet steel pre-galvanised, directly coupled to the three-phase electric motor with external rotor and IP54 protection and class F insulation. Fans are located in aerodynamically shaped structures, equipped with accident prevention steel guards.

## Refrigeration circuit

Two independent refrigeration circuits made of copper, brazed and factory-assembled, complete with:

- anti-acid dehydrator filter with solid cartridge complete with quick-fit connector for refrigerant;
- high-pressure safety pressure switch;
- economiser exchanger circuit;
- low pressure transducer;
- refrigerant temperature probe;
- electronic expansion valve;
- high and low pressure gauges;
- high pressure safety valve (safety valve with sealed tap open for inspection);
- low pressure safety valve (safety valve with sealed tap open for inspection);
- liquid flow and humidity indicator;
- cut-off valve on compressor supply circuit;
- cut-off valve on liquid line.

Suction pipes thermally insulated with highly flexible EPDM rubber closed-cell elastomer insulation. Each cooling circuit is tested under pressure for leaks and is supplied complete with load of refrigerant gas.

## Electrical panel

Entirely manufactured and wired in conformity to the EN 60204 standard. The power section includes:

- door locking main circuit breaker;
- main power supply terminals (400 V/3 Ph/50 Hz);
- insulation transformer for powering the auxiliary circuit (230 V/24 V);
- fuses and thermal relays for protecting the compressors;
- magneto-thermal cut-out switches to protect fans;
- compressor control contactor

The control section includes:

- interface terminal with graphic display;
- set values, error codes and parameters can be displayed;
- proportional-integral-derivative adjustment of water temperature;
- management of unit start-up from local or remote device;
- ON/OFF keys and alarm reset;
- daily, weekly temperature set point and start-up/shutdown scheduler;
- anti-freeze protection water side;
- compressor protection and timer;
- pre-alarm function for water anti-frost and refrigerant gas high pressure functions;
- self-diagnosis system with instant error code visualisation;
- control of compressor start-up automatic rotation;
- visualisation of no. of hours of compressor operation;
- remote ON/OFF control;

## Water circuit

Exclusive direct FREE-COOLING components

- 3-way valve or two 2-way valves (depending on models) with on/off control

Exclusive no-glycol FREE-COOLING components

- Water-water heat exchanger with braze-welded stainless steel. The exchanger is complete with antifreeze heaters and coating made of closed-cell heat insulating material.
- Pumping unit made up of two electropumps laid out in parallel with no-return valves, safety valves, antifreeze heaters, shut-off valves and drainage and thermoformed insulating casing

## Accessories

- Condensing coil protection grilles and technical compartment
- Condensing coil anti-hail protection grilles
- Copper / aluminium condensing coil with acrylic lining
- Copper / aluminium condensing coil with Aluminium Energy Guard DCC treatment
- Device for consumption reduction of the external section Ecobreeze fans
- Power factor correction capacitors (cosfi > 0.9)
- Serial communication module for Modbus supervisor
- Serial communication module for LonWorks supervisor
- Serial communication module for BACnet-IP supervisor
- ECOSHARE function for the automatic management of a group of units
- Compressor magnetothermic circuit breakers
- Progressive compressor start-up device
- Energy meter
- Set-point compensation with 0-10 V signal
- Set-point compensation with 4-20mA signal
- Set-point compensation with outdoor air temperature probe
- Electrical panel antifreeze protection
- Remote control via microprocessor remote control (separately supplied accessories)
- Mains power supply unit (separately supplied accessories)
- Spring antivibration mounts (separately supplied accessories)
- Couple of manually operated shut-off valves (separately supplied accessories)
- Unit supplied without glycol solution (only FCI configuration)

On request are available:

- Copper / copper condensing coil

## Test

Unit subjected to factory-tested in specific steps and test pressure of the piping of the refrigerant circuit (with nitrogen and hydrogen), before shipping them. After the approval, the moisture contents present in all circuits are analyzed, in order to ensure the respect of the limits set by the manufacturers of the different components.



## Unit equipment with outdoor air low temperatures

Minimum outdoor air temperature		Operating unit	Unit in stand-by (fed unit)	Unit in storage <sup>(5)</sup> (unit not fed)
+11°C	1	√ standard unit √ phase cutting fans (standard for SC conf., optional for EN conf.) √ ECOBREEZE fans (standard for EN conf., optional for SC conf.) √ Hydropack with n°. 2/3 of pumps (optional)	√ standard unit	
+2°C	2			
-7°C	3			
-10°C	4			
Between -10°C and -20°C		√ electrical panel antifreeze protection √ glycol in an appropriate percentage √ phase cutting fans (standard for SC conf., optional for EN conf.) √ ECOBREEZE fans (standard for EN conf., optional for SC conf.) √ Hydropack with n°. 2/3 of pumps (optional)	√ electrical panel antifreeze protection √ glycol in an appropriate percentage	√ standard unit
Between -20°C and -25°C		√ electrical panel antifreeze protection √ glycol in an appropriate percentage √ phase cutting fans (standard for SC conf., optional for EN conf.) √ ECOBREEZE fans (standard for EN conf., optional for SC conf.) ✗ <b>not suitable:</b> Hydropack with n°. 2/3 of pumps (optional)	√ electrical panel antifreeze protection √ glycol in an appropriate percentage ✗ <b>not suitable:</b> built-in pumps	✗ <b>not suitable:</b> built-in pumps
Between -25°C and -39°C		√ electrical panel antifreeze protection √ glycol in an appropriate percentage √ phase cutting fans (standard for SC conf., optional for EN conf.) ✗ <b>not suitable:</b> ECOBREEZE fans (standard for EN conf., optional for SC conf.) ✗ <b>not suitable:</b> Hydropack with n°. 2/3 of pumps (optional)	√ electrical panel antifreeze protection √ glycol in an appropriate percentage ✗ <b>not suitable:</b> built-in pumps	NOT POSSIBLE

Data referred to the following conditions:

internal exchanger water = 12/7°C

1. Part load unit and air speed equal to 1 m/s.
2. Part load unit and air speed equal to 0.5 m/s.
3. Part load unit and outdoor air temperature at rest.
4. Unit at full load and outdoor air temperature at rest.

<sup>(5)</sup> Unit without water or containing water with an appropriate quantity of glycol.

At the unit start-up the water temperature or water with glycol must be inside the operating range indicated in the "Operating range" graph.

To know the water freezing temperature on varying the glycol percentage refer to the specific 'Correction factors for glycol use' table.



Air conditions which are at rest are defined as the absence of air flowing towards the unit. Weak winds can induce air to flow through the exchanger and air-levels which can cause a reduction in the operating range. In the presence of predominant winds it is necessary to use suitable windbreak barriers.

## Minimum system water content

For a proper functioning of the unit a minimum water content has to be provided to the system, using the formula:

Minimum water content [l] = 7 x kWf (air conditioning application)

= 14 x kWf (application with low outdoor temperature or low loads required)

kWf = Nominal cooling capacity unit



Volume calculated does not consider internal heat exchanger (evaporator) water content.

# Unit configuration

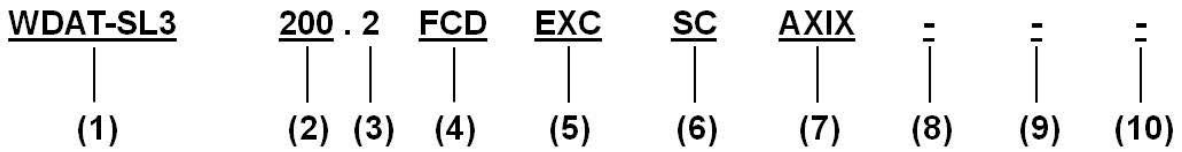

**(1) Range**

WDAT = Liquid chiller, air cooled, with screw compressors  
 SL3 = SCREWLine<sup>3</sup> range

**(2) Size**

200 = Nominal compressor capacity (HP)

**(3) Compressors**

2 = Compressor quantity

**(4) FREE-COOLING configuration**

FCD = Direct FREE-COOLING

FCL = No-glycol FREE-COOLING

**(5) Energy efficiency**

EXC = EXCELLENCE version: high energy efficiency

**(6) Acoustic configuration**

SC = Acoustic configuration with compressor soundproofing (standard)

EN = Super-silenced acoustic configuration

**(7) Fan diffusers**

AXIX - Diffuser for high efficiency fan (standard - separately supplied)

NAXI - Diffuser not required

**(8) Condensation heat recovery**

(-) Recovery not required (standard)

D - Partial energy recovery (15% of available heat)

**(9) Low evaporator water temperature configuration**

(-) Low water temperature: not required (standard)

B - Low water temperature, down to -8°C (Brine)

**(10) Pumping unit**

(-) Not required

2PM - Hydropack with no. 2 of pumps

3PM - Hydropack con no. 3 of pumps

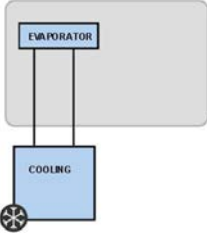
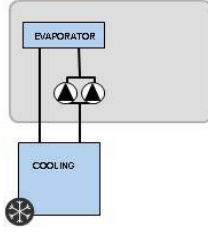
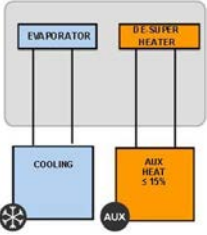
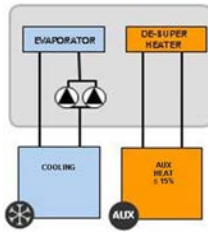
Functionalities	Hydronic units	
<p><b>2-PIPE SYSTEM</b></p> <p>Chilled water production for installation</p>	<p><b>1.1</b> Standard unit</p> 	<p><b>1.2</b> Standard unit with HYDROPACK</p> 
	<p><b>2.1</b> Standard unit with partial recovery</p> 	<p><b>2.2</b> Standard unit with partial recovery and HYDROPACK</p> 
<p><b>2-PIPE SYSTEM + PARTIAL RECOVERY</b></p> <p>Production of chilled water Free production of hot water from partial recovery</p>		

Accessories separately supplied		
• <b>RCMRX</b> - Remote control via microprocessor remote control	• <b>PSX</b> - Mains power supply unit	• <b>AMMX</b> - Spring antivibration mounts

# FCD / FCI CONFIGURATION

## Acoustic configuration: compressor soundproofing (SC)

### General technical data - Performance

Size			200.2	210.2	220.2	240.2	260.2	280.2	320.2	340.2	360.2	400.2	440.2	500.2	540.2	580.2
<b>Cooling</b>																
Cooling capacity	1	[kW]	469	503	527	567	622	675	752	814	868	942	1058	1183	1272	1375
Compressor power input	1	[kW]	137	148	154	166	185	199	223	238	259	284	323	349	384	417
Total power input	2	[kW]	150	162	170	182	202	218	243	261	281	309	349	380	416	450
Partial recovery heating capacity	3	[kW]	91	98	102	110	121	131	146	158	169	184	207	230	248	269
EER	1	-	3,12	3,11	3,11	3,12	3,09	3,10	3,09	3,12	3,08	3,05	3,03	3,11	3,06	3,06
Water flow-rate (User Side)	1	[l/s]	22,4	24,0	25,2	27,1	29,7	32,3	35,9	38,9	41,5	45,0	50,6	56,5	60,8	65,7
Total pressure drop user side - FCD	1	[kPa]	62,1	70,4	54,9	63,5	74,3	62,8	75,8	86,5	94,4	29,7	37,7	64,6	72,3	81,2
Total pressure drop user side - FCI	1	[kPa]	81,5	92,6	73,8	85,4	102	87,7	107	92,5	103	67,8	85,9	125	142	162
Cooling capacity (EN14511:2013)	4	[kW]	467	500	525	564	619	672	748	809	862	940	1056	1178	1266	1369
Total power input (EN14511:2013)	4	[kW]	152	164	172	184	205	221	247	265	287	311	351	385	421	456
EER (EN 14511:2013)	4	-	3,06	3,05	3,05	3,06	3,02	3,04	3,03	3,05	3,01	3,02	3,01	3,06	3,01	3,00
SEER	6	-	4,10	4,10	4,11	4,11	4,10	4,10	4,11	4,11	4,10	4,18	4,14	4,11	4,11	4,11
SEPR - FCD	7		6,09	6,16	6,16	6,24	6,20	6,10	6,11	6,00	6,00	6,07	6,12	6,16	6,12	6,26
SEPR - FCI	7		5,76	5,84	5,90	5,86	6,02	5,84	6,00	5,93	5,81	6,05	5,90	5,87	5,83	5,96
Cooling capacity (AHRI 550/590)	5	[kW]	466	499	523	562	618	670	746	805	856	935	1048	1174	1263	1365
Total power input (AHRI 550/590)	5	[kW]	150	161	169	181	201	217	242	259	279	308	348	380	414	448
COPR	5	-	3,11	3,10	3,10	3,10	3,08	3,08	3,08	3,10	3,06	3,03	3,01	3,09	3,05	3,05
IPLV	5	-	4,36	4,34	4,35	4,36	4,30	4,33	4,38	4,35	4,36	4,32	4,32	4,35	4,31	4,38

The Product is compliant with the Erp (Energy Related Products) European Directive. It includes the Commission delegated Regulation (EU) No 2016/2281, also known as Ecodesign Lot21.

\*Contains fluorinated greenhouse gases (GWP 2087,5)

- Data referred to the following conditions: internal exchanger water = 12/7 °C. Entering external exchanger air temperature 35°C. Evaporator fouling factor =  $0.44 \times 10^{(-4)}$  m<sup>2</sup> K/W
- The Total Power Input value does not take into account the part related to the pumps and required to overcome the pressure drops for the circulation of the solution inside the exchangers
- Recovery exchanger water=40/45°C
- Data compliant to Standard EN 14511:2013 referred to the following conditions: - Internal exchanger water temperature = 12/7°C - Entering external exchanger air temperature = 35°C
- Data compliant to Standard AHRI 550/590 referred to the following conditions: internal exchanger water temperature = 6,7 °C. Water flow-rate 0,043 l/s per kW. Entering external exchanger air temperature 35°C. Evaporator fouling factor =  $0.18 \times 10^{(-4)}$  m<sup>2</sup> K/W
- Data calculated according to the EN 14825:2016 Regulation
- Data calculated according to the EU 2016/2281 Regulation

## Acoustic configuration: super-silenced (EN)

### General technical data - Performance

Size			200.2	210.2	220.2	240.2	260.2	280.2	320.2	340.2	360.2	400.2	440.2	500.2
<b>Cooling</b>														
Cooling capacity	1	[kW]	464	496	521	565	616	672	737	810	850	935	1030	1166
Compressor power input	1	[kW]	143	150	161	168	189	207	221	247	263	283	320	363
Total power input	2	[kW]	148	155	166	174	194	214	229	255	271	292	329	372
Partial recovery heating capacity	3	[kW]	91	97	102	110	121	132	144	159	167	183	203	229
EER	1	-	3,13	3,21	3,14	3,25	3,17	3,14	3,23	3,18	3,14	3,21	3,13	3,14
Water flow-rate (User Side)	1	[l/s]	22	24	25	27	29	32	35	39	41	45	49	56
Total pressure drop user side - FCD	1	[kPa]	51,1	58,3	53,7	63,4	73,5	62,1	73,5	86,2	91,5	29,6	36,2	63,1
Total pressure drop user side - FCI	1	[kPa]	69,7	79,5	72,3	84,7	100	86,9	103	91,7	99,6	66,7	81,5	121
Cooling capacity (EN14511:2013)	4	[kW]	462	494	519	562	613	669	733	805	845	933	1028	1162
Total power input (EN14511:2013)	4	[kW]	150	157	168	176	197	216	232	259	276	293	332	376
EER (EN 14511:2013)	4	-	3,08	3,15	3,09	3,19	3,10	3,09	3,16	3,11	3,06	3,18	3,10	3,09
SEER	6	-	4,23	4,28	4,36	4,37	4,27	4,28	4,44	4,40	4,27	4,36	4,35	4,29
SEPR - FCD	7		6,89	7,13	7,24	7,16	7,16	6,87	6,72	6,90	6,83	7,05	6,65	6,75
SEPR - FCI	7		6,10	6,17	6,26	6,20	6,34	6,18	6,33	6,26	6,16	6,38	6,26	6,23
Cooling capacity (AHRI 550/590)	5	[kW]	461	492	517	560	612	666	731	801	838	927	1021	1158
Total power input (AHRI 550/590)	5	[kW]	148	154	165	173	194	213	228	254	269	291	328	371
COPR	5	-	3,13	3,19	3,13	3,23	3,16	3,13	3,21	3,16	3,12	3,19	3,11	3,12
IPLV	5	-	4,65	4,73	4,67	4,72	4,68	4,69	4,75	4,69	4,67	4,74	4,71	4,70

The Product is compliant with the Erp (Energy Related Products) European Directive. It includes the Commission delegated Regulation (EU) No 2016/2281, also known as Ecodesign Lot21.

\*Contains fluorinated greenhouse gases (GWP 2087,5)

- Data referred to the following conditions: internal exchanger water = 12/7 °C. Entering external exchanger air temperature 35°C. Evaporator fouling factor =  $0.44 \times 10^{(-4)}$  m<sup>2</sup> K/W
- The Total Power Input value does not take into account the part related to the pumps and required to overcome the pressure drops for the circulation of the solution inside the exchangers
- Recovery exchanger water=40/45°C
- Data compliant to Standard EN 14511:2013 referred to the following conditions: - Internal exchanger water temperature = 12/7°C - Entering external exchanger air temperature = 35°C
- Data compliant to Standard AHRI 550/590 referred to the following conditions: internal exchanger water temperature = 6,7 °C. Water flow-rate 0,043 l/s per kW. Entering external exchanger air temperature 35°C. Evaporator fouling factor =  $0.18 \times 10^{(-4)}$  m<sup>2</sup> K/W
- Data calculated according to the EN 14825:2016 Regulation
- Data calculated according to the EU 2016/2281 Regulation

# FCD / FCI CONFIGURATION

## Acoustic configuration: compressor soundproofing (SC)

### General technical data - Construction

Size		200.2	210.2	220.2	240.2	260.2	280.2	320.2	340.2	360.2	400.2	440.2	500.2	540.2	580.2	
<b>Compressor</b>																
Type of compressors	1	-	DSW	DSW	DSW	DSW	DSW	DSW	DSW	DSW	DSW	DSW	DSW	DSW	DSW	DSW
No. of compressors		Nr	2	2	2	2	2	2	2	2	2	2	2	2	2	2
Rated power (C1)		[HP]	100	100	110	120	120	140	160	160	180	200	220	250	270	290
Rated power (C2)		[HP]	100	110	110	120	140	140	160	180	180	200	220	250	270	290
Std Capacity control steps	6		25-100%	25-100%	25-100%	25-100%	25-100%	25-100%	25-100%	25-100%	25-100%	25-100%	25-100%	25-100%	25-100%	25-100%
Oil charge (C1)		[l]	17	17	17	17	17	21	21	21	25	25	25	25	30	30
Oil charge (C2)		[l]	17	17	17	17	21	21	21	25	25	25	25	25	30	30
Refrigerant charge (C1)		[kg]	72	72	69	80	80	97	97	95	108	124	126	142	160	161
Refrigerant charge (C2)		[kg]	69	69	69	80	81	97	97	114	114	130	135	150	169	170
Refrigeration circuits		-	2	2	2	2	2	2	2	2	2	2	2	2	2	2
<b>Internal exchanger (evaporator)</b>																
Type of internal exchanger	2	-	S&T	S&T	S&T	S&T	S&T	S&T	S&T	S&T	S&T	S&T	S&T	S&T	S&T	S&T
N. of internal exchanger		Nr	1	1	1	1	1	1	1	1	1	1	1	1	1	1
<b>External exchanger (condenser)</b>																
Frontal surface		m <sup>2</sup>	18,7	18,7	23,4	23,4	23,4	28,1	28,1	32,8	32,8	37,4	37,4	46,8	46,8	46,8
<b>External Section Fans</b>																
Type of fans	3	-	AX	AX	AX	AX	AX	AX	AX	AX	AX	AX	AX	AX	AX	AX
Number of fans		Nr	8	8	10	10	10	12	12	14	14	16	16	20	20	20
Type of motor	4	-	AC/P	AC/P	AC/P	AC/P	AC/P	AC/P	AC/P	AC/P	AC/P	AC/P	AC/P	AC/P	AC/P	AC/P
Standard airflow		[l/s]	42160	42160	52700	52700	52700	63250	63250	73800	73800	84300	84300	105400	105400	105400
<b>Connections</b>																
Water fittings		-	8"	8"	6"	6"	6"	6"	6"	6"	6"	8"	8"	8"	8"	8"
<b>Water content</b>																
Water content FCD		[l]	671	672	827	827	829	866	865	951	951	1237	1237	1635	1635	1635
Water content FCI		[l]	409	409	436	442	449	470	475	541	551	975	997	885	894	905
<b>Power supply</b>																
Standard power supply		-	400/3~/50	400/3~/50	400/3~/50	400/3~/50	400/3~/50	400/3~/50	400/3~/50	400/3~/50	400/3~/50	400/3~/50	400/3~/50	400/3~/50	400/3~/50	400/3~/50
<b>Electrical data - FCD</b>																
F.L.A. - Total		A	369,7	387,9	414,3	439,7	488,5	545,5	599,5	647,5	687,3	751,3	819,3	916,3	982,3	1047,1
F.L.I. - Total		kW	225	236,3	251,5	267,5	292,3	321	352,8	381	405,3	442,4	493,4	545,4	594,2	634,2
M.I.C. - Value	5	A	355,9	408,9	426,7	436,2	432,2	472,9	559,2	657,3	687,1	712,1	808,6	956,1	1095,8	1253,1
M.I.C. - with soft start accessory	5	A	516,9	597,9	615,7	630,2	615,2	655,9	786,2	978,3	1008,1	1034,1	1167,6	1380,1	1668,8	1853,1
<b>Electrical data - FCI</b>																
F.L.A. - Total		A	387,1	405,3	431,7	457,1	505,9	562,9	620,3	668,3	714,5	778,5	846,5	956,7	1022,7	1087,5
F.L.I. - Total		kW	233	244,3	259,5	275,5	300,3	329	363,8	392	420,3	457,4	508,4	567,4	616,2	656,2
M.I.C. - Value	5	A	355,9	408,9	426,7	436,2	432,2	472,9	559,2	657,3	687,1	712,1	808,6	956,1	1095,8	1253,1
M.I.C. - with soft start accessory	5	A	516,9	597,9	615,7	630,2	615,2	655,9	786,2	978,3	1008,1	1034,1	1167,6	1380,1	1668,8	1853,1

1. DSW = double screw compressor
2. S&T = shell and tube
3. AX = axial fan
4. AC/P = asynchronous three-phase external rotor motor with phase cutting speed automatic control

- Unbalance between phase max 2%      Voltage variation: max +/- 10%
- Electrical data refer to standard units; according to the installed accessories, the data can suffer some variations.
5. M.I.C. = compressor 2 starting current + compressor 1 current at 75% of the max load + circuit 1 fan
  6. The unit is able to modulate STEPLESS continuously. The following data refers to a continuous operation of the unit. During start-up and stop, each compressor is able to modulate up to 25% of its capacity

# FCD / FCI CONFIGURATION

## Acoustic configuration: super-silenced (EN)

### General technical data - Construction

Size			200.2	210.2	220.2	240.2	260.2	280.2	320.2	340.2	360.2	400.2	440.2	500.2
<b>Compressor</b>														
Type of compressors	1	-	DSW	DSW	DSW	DSW	DSW	DSW	DSW	DSW	DSW	DSW	DSW	DSW
No. of compressors		Nr	2	2	2	2	2	2	2	2	2	2	2	2
Rated power (C1)		[HP]	100	100	110	120	120	140	160	160	180	200	220	250
Rated power (C2)		[HP]	100	110	110	120	140	140	160	180	180	200	220	250
Std Capacity control steps	6		25-100%	25-100%	25-100%	25-100%	25-100%	25-100%	25-100%	25-100%	25-100%	25-100%	25-100%	25-100%
Oil charge (C1)		[l]	17	17	17	17	17	21	21	21	25	25	25	25
Oil charge (C2)		[l]	17	17	17	17	21	21	21	25	25	25	25	25
Refrigerant charge (C1)		[kg]	66	66	77	80	91	106	118	118	119	133	155	159
Refrigerant charge (C2)		[kg]	66	66	77	80	92	113	124	125	125	139	164	168
Refrigeration circuits		-	2	2	2	2	2	2	2	2	2	2	2	2
<b>Internal exchanger (evaporator)</b>														
Type of internal exchanger	2	-	S&T	S&T	S&T	S&T	S&T	S&T	S&T	S&T	S&T	S&T	S&T	S&T
N. of internal exchanger		Nr	1	1	1	1	1	1	1	1	1	1	1	1
<b>External exchanger (condenser)</b>														
Frontal surface		m <sup>2</sup>	18,7	18,7	23,4	23,4	23,4	28,1	28,1	32,8	32,8	37,4	37,4	46,8
<b>External Section Fans</b>														
Type of fans	3	-	AX	AX	AX	AX	AX	AX	AX	AX	AX	AX	AX	AX
Number of fans		Nr	10	10	10	12	12	14	16	16	16	20	20	20
Type of motor	4	-	EC	EC	EC	EC	EC	EC	EC	EC	EC	EC	EC	EC
Standard airflow		[l/s]	33700	33700	33700	44500	44500	47200	54000	54000	54000	67500	67500	67500
<b>Connections</b>														
Water fittings		-	6"	6"	6"	6"	6"	6"	6"	6"	6"	8"	8"	8"
<b>Water content</b>														
Water content FCD		[l]	521	521	521	585	585	670	756	756	756	1122	1122	1122
Water content FCI		[l]	429	433	436	469	474	489	516	560	571	821	832	885
<b>Power supply</b>														
Standard power supply		V	400/3~/50	400/3~/50	400/3~/50	400/3~/50	400/3~/50	400/3~/50	400/3~/50	400/3~/50	400/3~/50	400/3~/50	400/3~/50	400/3~/50
<b>Electrical data - FCD</b>														
F.L.A. - Total		A	359,2	377,4	395,6	425,5	474,3	527,5	586	625,8	665,6	730,3	798,3	878,9
F.L.I. - Total		kW	221,5	232,8	244,1	262,5	287,3	314,5	348,7	373	397,3	435,4	486,4	530,6
M.I.C. - Value	5	A	350,7	403,7	417,3	429,1	425,1	463,9	552,4	646,4	676,2	701,6	798,1	937,4
M.I.C. - with soft start accessory	5	A	511,7	592,7	606,3	623,1	608,1	646,9	779,4	967,4	997,2	1023,6	1157,1	1361,4
<b>Electrical data - FCI</b>														
F.L.A. - Total		A	376,6	394,8	413	442,9	491,7	544,9	606,8	646,6	692,8	757,5	825,5	906,1
F.L.I. - Total		kW	229,5	240,8	252,1	270,5	295,3	322,5	359,7	384	412,3	450,4	501,4	552,6
M.I.C. - Value	5	A	350,7	403,7	417,3	429,1	425,1	463,9	552,4	646,4	676,2	701,6	798,1	937,4
M.I.C. - with soft start accessory	5	A	511,7	592,7	606,3	623,1	608,1	646,9	779,4	967,4	997,2	1023,6	1157,1	1361,4

1. DSW = double screw compressor

2. S&T = shell and tube

3. AX = axial fan

4. EC = electronic permanent-magnet switching motor without brushes with speed automatic control

Unbalance between phase max 2% Voltage variation: max +/- 10%

Electrical data refer to standard units; according to the installed accessories, the data can suffer some variations.

5. M.I.C. = compressor 2 starting current + compressor 1 current at 75% of the max load + circuit 1 fan

6. The unit is able to modulate STEPLESS continuously. The following data refers to a continuous operation of the unit. During start-up and stop, each compressor is able to modulate up to 25% of its capacity

# Operating range

## FCD / FCI CONFIGURATION

### Acoustic configuration: compressor soundproofing (SC)

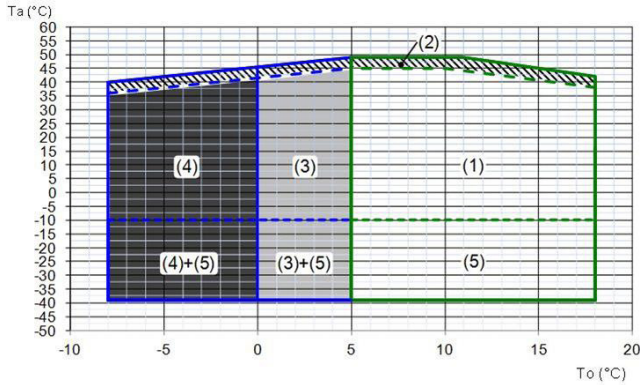

### Acoustic configuration: super-silenced (EN)

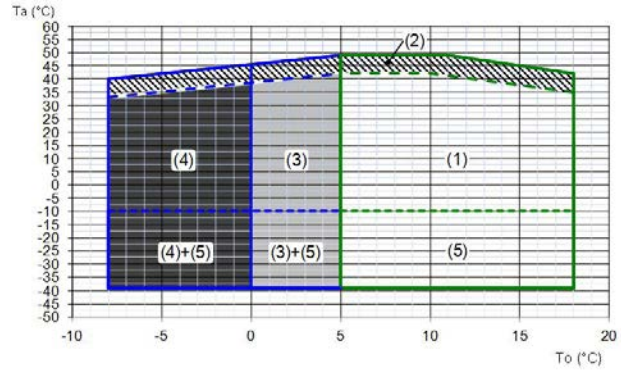

Ta (°C) = external exchanger inlet air temperature (D.B.)  
To (°C) = internal exchanger outlet water temperature

1. Standard unit operating range at full load
2. Unit operating range with automatic staging of the compressor capacity
3. Unit operating range in 'B - Low water temperature' configuration (40% ethylene glycol)
4. Extended of operating range (extremely low water temperature option available on request)
5. Unit operating range as "Unit equipment with outdoor air low temperatures" table

Ta (°C) = temperatura aria entrante allo scambiatore esterno (D.B.)  
To (°C) = internal exchanger outlet water temperature

1. Standard unit operating range at full load
2. Unit operating range with automatic staging of the compressor capacity
3. Unit operating range in 'B - Low water temperature' configuration (40% ethylene glycol)
4. Extended of operating range (extremely low water temperature option available on request)
5. Unit operating range as "Unit equipment with outdoor air low temperatures" table

# Sound levels

### Acoustic configuration: compressor soundproofing (SC)

Size	Sound power level (dB)								Sound power level dB(A)	Sound pressure level dB(A)
	Octave band (Hz)									
	63	125	250	500	1000	2000	4000	8000		
200.2	107	98	86	92	97	73	76	72	98	77
210.2	107	98	90	92	97	74	76	72	98	77
220.2	108	99	92	92	97	75	77	74	98	77
240.2	108	99	91	94	97	76	77	74	98	77
260.2	108	99	90	93	96	81	79	74	98	77
280.2	110	100	90	94	96	84	81	75	98	77
320.2	110	100	90	94	97	84	81	75	98	77
340.2	111	101	91	95	98	85	82	76	100	78
360.2	111	101	92	96	99	86	82	76	100	79
400.2	112	102	95	95	101	84	82	77	102	80
440.2	112	102	92	101	102	85	82	77	104	82
500.2	113	103	92	95	104	89	84	78	105	82
540.2	113	103	96	94	105	86	85	78	106	83
580.2	113	103	92	96	105	89	84	78	106	83

### Acoustic configuration: super-silenced (EN)

Size	Sound power level (dB)								Sound power level dB(A)	Sound pressure level dB(A)
	Octave band (Hz)									
	63	125	250	500	1000	2000	4000	8000		
200.2	96	90	81	89	93	68	66	61	94	73
210.2	96	90	85	88	93	69	66	61	94	73
220.2	96	90	88	88	93	70	66	61	94	73
240.2	97	91	87	90	93	71	68	62	94	73
260.2	97	90	86	89	93	77	72	63	94	73
280.2	98	89	85	90	92	80	74	64	94	72
320.2	99	90	85	90	93	80	75	65	94	73
340.2	99	90	87	91	94	81	76	65	95	74
360.2	99	90	88	92	95	82	76	65	96	74
400.2	100	92	91	91	97	81	76	66	98	76
440.2	100	92	88	98	99	81	75	66	100	78
500.2	100	92	87	90	100	84	78	66	100	78

The sound levels refer to standard unit with Axitop (no accessories) at full load, in test nominal conditions. The sound pressure level refers to 1 m. from the standard unit outer surface operating in open eld. Measures are according to UNI EN ISO 9614-2 regulations, with respect to the EUROVENT 8/1 certification, which provides for a tolerance of 3 dB(A) on the sound power level, which is the only acoustic data to be considered binding. If unit is set without Axitop, the sound power level presents an increase up to 3 dB(A).  
Data referred to the following conditions:  
- internal exchanger water = 12/7 °C  
- ambient temperature = 35 °C

## Admissible water flow-rates

Minimum (Qmin) and maximum (Qmax) admissible water flow for the unit to operate correctly.

EXCELLENCE SC		200.2	210.2	220.2	240.2	260.2	280.2	320.2	340.2	360.2	400.2	440.2	500.2	540.2	580.2
Qmin	[l/s]	15.3	15.3	20.1	20.1	20.1	21.6	21.6	21.6	21.6	39.4	39.4	32.3	32.3	32.3
Qmax	[l/s]	37.3	37.3	45.2	45.2	45.2	53.4	53.4	53.4	53.4	86.6	86.6	72.5	72.5	72.5

EXCELLENCE EN		200.2	210.2	220.2	240.2	260.2	280.2	320.2	340.2	360.2	400.2	440.2	500.2
Qmin	[l/s]	17.5	17.5	20.1	20.1	20.1	21.6	21.6	21.6	21.6	39.4	39.4	32.3
Qmax	[l/s]	37.9	37.9	45.2	45.2	45.2	53.4	53.4	53.4	53.4	86.6	86.6	72.5

## Correction factors for glycol use

% ethylene glycol by weight		5%	10%	15%	20%	25%	30%	35%	40%	50%	60%
Freezing temperature	°C	-2,0	-3,9	-6,5	-8,9	-11,8	-15,6	-19,0	-23,4	-33,0	-39,0
Safety temperature	°C	3,0	1,0	-1,0	-4,0	-6,0	-10,0	-14,0	-19,0	-30,0	-36,0
Cooling Capacity Factor	No	0,995	0,989	0,983	0,977	0,971	0,964	0,956	0,949	0,933	0,926
Compressor power input Factor	No	1,0011	1,0022	1,003	1,004	1,006	1,007	1,008	1,009	1,0110	1,0119
Internal exchanger glycol solution flow factor	No	1,003	1,01	1,02	1,033	1,05	1,072	1,095	1,124	1,192	1,229
Pressure drop Factor	No	1,05	1,10	1,15	1,20	1,25	1,30	1,35	1,40	1,50	1,55

## Fouling Correction Factors

m <sup>2</sup> °C / W	Internal exchanger (evaporator)	
	F1	FK1
<b>0.44 x 10 (-4)</b>	1,0	1,0
<b>0.88 x 10 (-4)</b>	0,97	0,99
<b>1.76 x 10 (-4)</b>	0,94	0,98

F1 = Cooling capacity correction factors

FK1 = Compressor power input correction factor

## Exchanger operating range

PED (CE)	Internal exchanger	
	DPr	DPw
	2450	1050

DPr = Maximum operating pressure on refrigerant side in kPa

DPw = Maximum operating pressure on water side in kPa

## Overload and control device calibrations

		open	closed	value
High pressure switch	[kPa]	2100	1550	–
Antifreeze protection	[°C]	3	5.5	–
High pressure safety valve	[kPa]	–	–	2500
Low pressure safety valve	[kPa]	–	–	1650
Max no. of compressor starts per hour	[n°]	–	–	6
Discharge safety thermostat	[°C]	–	–	120

# FCD / FCI CONFIGURATION

## Acoustic configuration: compressor soundproofing (SC)

### Cooling performance

(continued)

Size	To (°C)	Entering external exchanger air temperature (°C)											
		25		30		35		40		45		49	
		kWf	kWe	kWf	kWe	kWf	kWe	kWf	kWe	kWf	kWe	kWf	kWe
200.2	5	478	112	460	122	439	134	415	146	393	160	314	148
	6	493	114	474	124	452	135	429	148	407	161	325	150
	7	510	115	489	125	469	137	446	150	420	164	336	152
	10	558	120	539	131	515	143	491	156	463	170	370	158
	15	646	129	625	140	603	153	575	167	467	149	-	-
	18	697	135	676	147	655	160	569	156	-	-	-	-
210.2	5	513	121	492	132	469	144	445	158	419	172	336	158
	6	531	123	508	134	484	146	460	160	433	174	348	160
	7	547	125	526	136	503	148	476	162	449	177	360	163
	10	599	130	578	141	551	155	524	168	494	184	397	170
	15	693	140	670	153	644	167	612	181	498	161	-	-
	18	751	147	722	160	697	174	606	169	-	-	-	-
220.2	5	536	126	516	138	495	150	467	164	443	179	341	154
	6	552	127	533	139	511	152	483	166	458	181	352	156
	7	569	129	549	141	527	154	502	169	474	183	365	158
	10	622	135	601	146	578	160	552	175	522	191	401	164
	15	722	146	700	158	671	172	645	187	526	167	-	-
	18	775	152	757	166	726	180	638	175	-	-	-	-
240.2	5	579	135	556	148	533	161	506	177	477	191	387	174
	6	594	137	574	150	550	163	523	179	493	194	400	177
	7	614	139	592	152	567	166	540	181	511	197	416	180
	10	669	145	648	158	622	172	594	188	562	206	457	187
	15	776	157	746	170	723	186	689	202	567	180	-	-
	18	835	164	813	179	785	195	682	188	-	-	-	-
260.2	5	636	151	612	165	584	180	555	196	525	214	420	188
	6	652	153	632	167	603	182	573	199	542	217	434	191
	7	672	156	651	169	622	185	592	202	563	221	450	194
	10	737	163	711	177	681	193	650	210	618	230	495	203
	15	844	176	818	192	789	209	755	227	624	202	-	-
	18	907	184	878	200	854	219	747	212	-	-	-	-
280.2	5	687	164	660	178	631	193	600	211	567	229	419	184
	6	707	166	684	181	655	196	620	214	586	232	433	187
	7	731	169	704	183	675	199	644	217	608	236	450	190
	10	798	178	774	191	738	208	707	226	667	247	494	199
	15	923	193	893	209	859	227	825	245	673	216	-	-
	18	986	203	956	220	927	237	816	229	-	-	-	-
320.2	5	767	184	740	199	708	217	674	236	634	255	462	203
	6	790	186	762	202	730	220	695	239	654	259	477	207
	7	813	189	786	204	752	223	717	243	680	263	496	210
	10	886	199	856	215	822	234	786	253	745	276	543	220
	15	1016	217	981	235	947	254	917	278	751	242	-	-
	18	1094	231	1059	249	1029	268	907	259	-	-	-	-
340.2	5	829	193	802	211	768	230	728	252	684	276	478	217
	6	859	197	827	214	791	234	752	256	711	278	497	218
	7	886	199	854	216	814	238	780	259	739	282	517	222
	10	963	207	934	225	898	246	855	269	810	295	566	232
	15	1111	222	1080	242	1033	264	994	289	818	258	-	-
	18	1203	231	1171	253	1124	276	983	269	-	-	-	-
360.2	5	889	212	854	230	814	253	776	274	723	300	456	209
	6	915	215	883	233	841	256	800	278	750	303	473	211
	7	944	217	909	236	868	259	826	282	776	310	489	216
	10	1040	227	997	245	955	269	909	294	858	321	541	223
	15	1200	244	1150	265	1115	290	1055	316	865	281	-	-
	18	1275	253	1244	278	1208	303	1044	295	-	-	-	-



Size	To (°C)	Entering external exchanger air temperature (°C)											
		25		30		35		40		45		49	
		kWf	kWe	kWf	kWe	kWf	kWe	kWf	kWe	kWf	kWe	kWf	kWe
400.2	5	964	232	927	253	886	276	841	301	788	327	549	247
	6	994	235	958	255	915	279	870	305	820	333	571	251
	7	1023	238	987	259	942	284	899	308	847	337	590	255
	10	1126	250	1089	270	1044	296	993	324	934	354	651	268
	15	1299	268	1254	293	1205	320	1161	349	942	310	-	-
	18	1403	281	1357	307	1306	334	1149	326	-	-	-	-
440.2	5	1076	264	1036	286	987	313	934	341	879	372	644	290
	6	1116	269	1076	291	1019	317	973	347	907	378	664	294
	7	1150	272	1106	296	1058	323	1003	352	935	384	685	299
	10	1256	284	1208	310	1158	338	1107	370	1035	403	758	314
	15	1442	307	1387	338	1334	366	1268	399	1044	352	-	-
	18	1558	325	1502	353	1443	383	1255	373	-	-	-	-
500.2	5	1198	286	1164	310	1112	339	1057	370	1002	401	752	318
	6	1243	291	1199	315	1148	344	1091	375	1030	409	773	324
	7	1280	295	1236	319	1183	349	1128	380	1064	415	798	329
	10	1400	309	1360	335	1303	366	1236	397	1169	433	876	343
	15	1591	332	1551	364	1506	396	1427	430	1179	379	-	-
	18	1718	351	1674	383	1626	416	1412	401	-	-	-	-
540.2	5	1303	316	1255	342	1198	374	1135	407	1074	441	752	281
	6	1341	321	1294	346	1236	378	1171	413	1106	448	773	285
	7	1381	325	1331	353	1272	384	1213	417	1142	455	802	289
	10	1505	341	1462	372	1400	405	1337	438	1263	478	878	304
	15	1723	371	1658	404	1603	436	1556	481	1326	418	-	-
	18	1874	396	1821	429	1744	463	1540	448	-	-	-	-
580.2	5	1401	343	1361	371	1296	405	1230	439	1162	479	776	345
	6	1453	348	1401	377	1336	410	1269	445	1194	484	797	348
	7	1495	354	1442	383	1375	417	1310	452	1240	493	828	355
	10	1632	370	1580	406	1514	439	1444	478	1356	518	906	373
	15	1858	405	1789	441	1736	479	1656	526	1369	453	-	-
	18	2035	437	1960	469	1880	508	1638	490	-	-	-	-

kWf = Cooling capacity in kW

kWe = Compressor power input in kW

To (°C) = internal exchanger outlet water temperature (evaporator)

Performances in function of the inlet/outlet water temperature differential = 5°C

The data do not consider the part related to the pumps, required to overcome the pressure drop for the solution circulation inside the exchangers

## Total pressure drop

### FCD - Direct FREE-COOLING

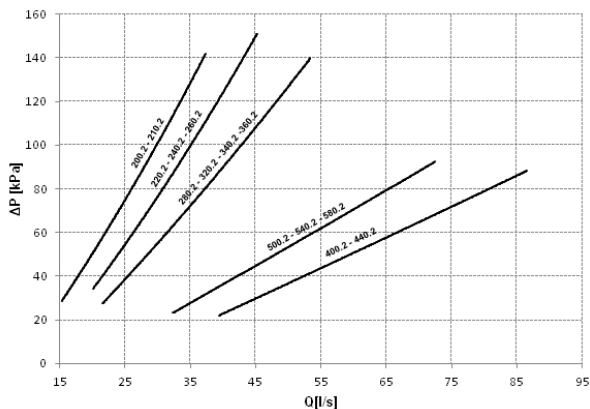

### FCI - No-glycol FREE-COOLING

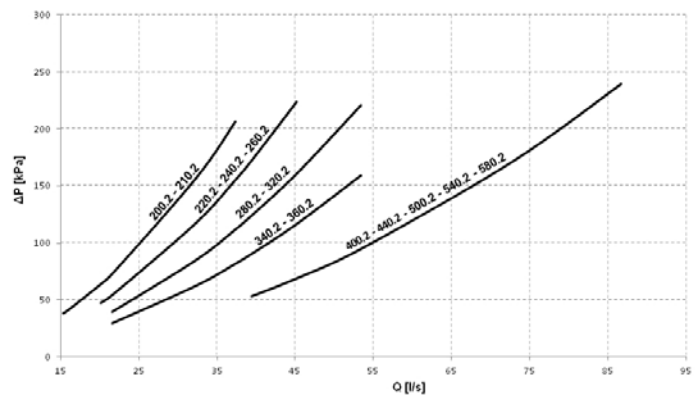

Q = water flow-rate [l/s]

DP = pressure drop water side [kPa]



To the internal exchanger pressure drops must be added the pressure drops of the steel mesh mechanical filter (not supplied) that must be placed on the water input line. It is a device compulsory for the correct unit operation and it must be selected and installed by the Customer. It is forbidden the use of filters with the mesh pitch higher than 1,0 mm. Filters with higher mesh pitch can cause a bad unit operation and also its serious damaging.

# FCD / FCI CONFIGURATION

Acoustic configuration: super-silenced (EN)

## Cooling performance

(continued)

Size	To (°C)	Entering external exchanger air temperature(°C)											
		25		30		35		40		42		49	
		kWf	kWe	kWf	kWe	kWf	kWe	kWf	kWe	kWf	kWe	kWf	kWe
200.2	5	475	117	455	127	436	140	412	152	401	158	249	104
	6	490	118	471	129	450	141	425	154	415	160	257	105
	7	507	120	485	131	464	143	440	156	431	162	267	107
	10	555	126	535	137	509	149	486	163	473	169	293	112
	15	638	135	618	148	592	162	570	171	540	168	-	-
	18	690	142	673	156	647	170	590	165	599	155	-	-
210.2	5	509	122	488	133	466	146	440	159	430	165	275	109
	6	524	124	504	135	481	148	454	162	444	167	284	111
	7	541	126	519	137	496	150	471	164	461	169	295	112
	10	592	132	570	144	545	157	518	171	506	178	324	118
	15	683	143	660	156	631	170	608	180	578	176	-	-
	18	737	150	715	164	690	179	631	173	584	163	-	-
220.2	5	537	131	513	142	488	156	463	170	452	175	365	158
	6	553	133	529	144	503	158	478	173	466	178	377	160
	7	569	135	549	147	521	161	494	175	482	181	389	163
	10	627	142	599	154	573	169	544	184	530	190	428	171
	15	726	155	695	169	666	182	638	193	605	188	-	-
	18	782	163	754	178	722	192	660	187	611	175	-	-
240.2	5	577	137	554	150	528	163	499	178	490	184	378	152
	6	595	139	572	152	545	165	518	181	506	186	390	154
	7	612	141	590	154	565	168	535	183	523	189	403	156
	10	671	148	647	160	618	176	591	191	577	198	445	163
	15	772	160	747	175	716	189	693	201	660	196	-	-
	18	834	168	811	184	783	200	717	193	667	181	-	-
260.2	5	630	154	608	167	578	183	548	199	536	206	351	144
	6	649	156	627	170	597	186	568	202	554	209	363	146
	7	668	158	646	172	616	189	586	205	572	212	374	148
	10	733	167	706	181	675	197	645	215	630	222	413	155
	15	838	181	812	197	779	214	757	226	720	221	-	-
	18	906	192	879	208	847	227	780	219	724	205	-	-
280.2	5	687	169	659	184	627	201	595	219	581	227	430	184
	6	708	172	680	186	648	204	612	223	602	229	445	185
	7	730	174	706	189	672	207	636	226	622	233	460	188
	10	803	182	773	197	738	216	701	235	682	244	504	197
	15	936	196	898	214	859	234	823	247	779	242	-	-
	18	1005	205	970	225	938	244	856	238	794	224	-	-
320.2	5	758	181	725	196	694	215	657	235	639	243	490	206
	6	782	183	748	199	716	218	678	238	664	246	509	208
	7	805	186	776	202	737	221	700	242	685	250	525	212
	10	880	194	850	211	814	231	771	251	752	261	577	221
	15	1016	209	982	228	949	250	906	263	859	259	-	-
	18	1105	220	1061	239	1020	260	943	256	869	240	-	-
340.2	5	829	202	795	219	758	240	719	262	701	271	483	204
	6	855	205	823	223	783	244	743	266	725	275	499	207
	7	880	208	848	226	810	247	768	270	749	280	516	211
	10	961	217	928	236	887	259	845	283	822	293	567	220
	15	1118	236	1068	257	1031	280	992	297	939	291	-	-
	18	1191	246	1154	269	1113	294	1024	286	948	270	-	-
360.2	5	872	216	840	233	799	256	758	279	736	289	560	243
	6	899	219	865	237	823	261	784	282	760	293	579	246
	7	926	222	891	241	850	263	807	287	789	299	600	251
	10	1011	232	974	252	931	276	883	301	862	313	656	262
	15	1172	252	1119	275	1083	299	1037	316	984	310	-	-
	18	1264	266	1219	289	1166	315	1085	307	995	289	-	-

Size	To (°C)	Entering external exchanger air temperature (°C)											
		25		30		35		40		42		49	
		kWf	kWe	kWf	kWe	kWf	kWe	kWf	kWe	kWf	kWe	kWf	kWe
400.2	5	955	232	918	252	878	275	825	298	803	307	610	252
	6	984	235	947	256	907	279	857	304	837	316	636	259
	7	1013	238	977	259	935	283	889	309	867	320	659	262
	10	1114	250	1070	273	1024	296	977	322	957	333	727	273
	15	1283	271	1236	296	1189	321	1147	338	1093	330	-	-
	18	1385	283	1338	309	1288	336	1201	328	1109	307	-	-
440.2	5	1049	265	1008	287	962	310	918	342	894	354	723	289
	6	1082	267	1046	292	999	316	948	347	922	359	748	294
	7	1123	273	1077	297	1030	320	978	352	954	363	771	297
	10	1223	286	1175	311	1125	336	1071	368	1050	383	841	313
	15	1399	310	1349	338	1298	363	1258	387	1199	380	-	-
	18	1507	327	1460	356	1397	382	1292	374	1199	352	-	-
500.2	5	1183	299	1135	324	1094	352	1031	384	1006	396	744	314
	6	1217	303	1168	329	1130	358	1065	390	1041	405	770	322
	7	1256	306	1203	334	1166	363	1103	399	1073	412	793	327
	10	1365	322	1309	352	1262	381	1202	420	1170	434	865	344
	15	1550	351	1505	382	1451	414	1412	441	1337	431	-	-
	18	1683	374	1618	405	1560	439	1449	428	1335	400	-	-

kWf = Cooling capacity in kW  
 kWe = Compressor power input in kW  
 To (°C) = internal exchanger outlet water temperature (evaporator)  
 Performances in function of the inlet/outlet water temperature differential = 5°C  
 The data do not consider the part related to the pumps, required to overcome the pressure drop for the solution circulation inside the exchangers

## Total pressure drop

### FCD - Direct FREE-COOLING

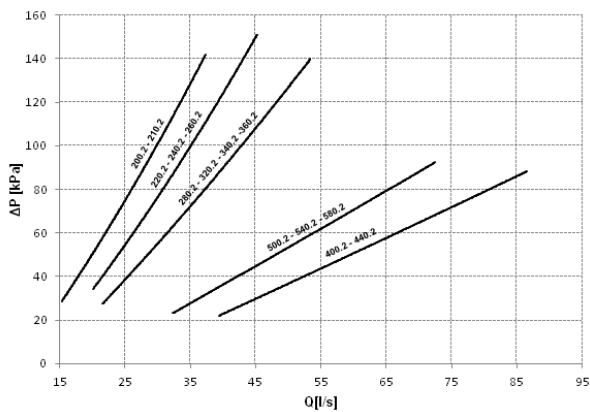

### FCI - No-glycol FREE-COOLING

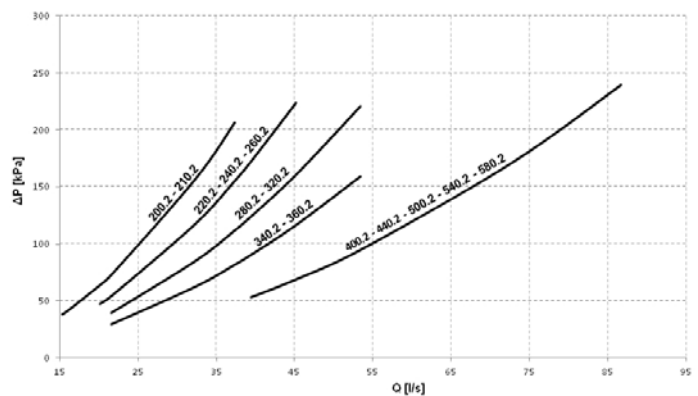

Q = water flow-rate [l/s]  
 DP = pressure drop water side [kPa]



To the internal exchanger pressure drops must be added the pressure drops of the steel mesh mechanical filter (not supplied) that must be placed on the water input line. It is a device compulsory for the correct unit operation and it must be selected and installed by the Customer. It is forbidden the use of filters with the mesh pitch higher than 1,0 mm. Filters with higher mesh pitch can cause a bad unit operation and also its serious damaging.

## FCD - Direct FREE-COOLING

Configuration that allows for considerable savings on the system's running costs in applications that require chilled water also during the cold season, such as industrial processes, data centres, telecommunications, technological applications and shopping centres. When the outdoor air temperature is lower than the temperature of the system's return water, the FREE-COOLING system recovers cold from the external environment and reduces the operation of the compressors until they stop completely. The higher the temperature of the chilled water in the system (e.g. 10-15°C instead of 7-12°C), the greater the operating range of the FREE-COOLING system and, therefore, the higher the energy savings.

### Use of anti-freeze solutions

The FREE-COOLING configuration is particularly indicated in buildings where, at least in certain periods of the year, the temperature of the outdoor air also reaches very low values. For this reason the liquid must be protected from the risk of freezing, typically using the addition of a suitable anti-freeze substance such as ethylene glycol. The percentage of glycol in the solution depends on the minimum temperature value foreseen in the installation zone, and is in any case within the fundamental parameters of the plan for the system.

### Management logic

There are three main operating modes, which basically differ in terms of position of the three-way switching valve and the number of active compressors.

#### (A) Summer

In the summer season, with outdoor air temperatures which are greater than the return temperature of the liquid in the system, the three-way valve is switched in such a way as to exclude the FREE-COOLING coils. The cooling of the liquid is referred to the direct expansion circuit, with the intervention of the compressors as in a traditional chiller.

#### (B) Intermediate season

In the winter season, or rather with the outdoor air temperature at a little below the return water temperature of the system, when the unit identifies that the temperature conditions are favourable:

- switches the position of the three-way valve, forcing the solution to transit through the FREE-COOLING coils before reaching the evaporator
- brings the fans to maximum speed to make the most of the cooling of the solution carried out by the outdoor air
- conducts a first cooling of the solution in a 'natural way and free of charge'
- provides any missing capacity via the cooling circuit using compressors with partial operation (power input proportional to the partialisation level)

If the outdoor air temperature should increase, the microprocessor automatically converts the operating mode to the summer mode, guaranteeing the conditions requested by the user at all times.

#### (C) Winter

In the winter season, with the outdoor air temperature below the return water temperature of the system, the unit identifies that the temperature conditions are favourable for operating in FREE-COOLING mode:

- the 3-way valve is switched like in the previous case, forcing the solution to transit through the FREE-COOLING coils before reaching the evaporator.
- the outdoor air temperature brings the solution at the outlet of the FREE-COOLING coils already at the temperature required by the utility
- the microprocessor control completely deactivates all the compressors which supply all the requested cooling capacity at no cost, in contrast to traditional chillers

The difference between the outdoor air temperature and that requested for use could also be such as to lower the temperature of the solution at the output of the FREE-COOLING coils to below the set-point requested for use. This is a condition which does not prejudice the safety of the unit thanks to the presence of anti-freeze in the solution. The microprocessor modulates fan speed up to the point where they are switched off. If, with all the fans switched, off the temperature continues to decrease, the three-way valve positions itself automatically in the summer operational mode, thus enabling the requested set-point to be maintained.

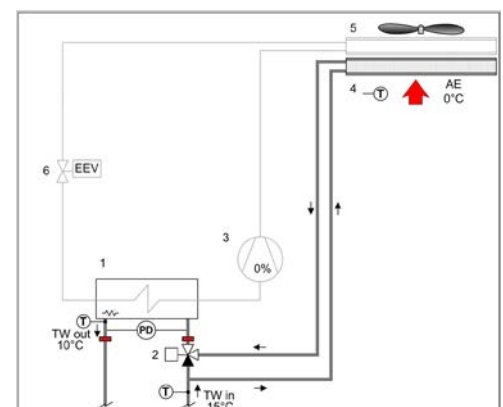
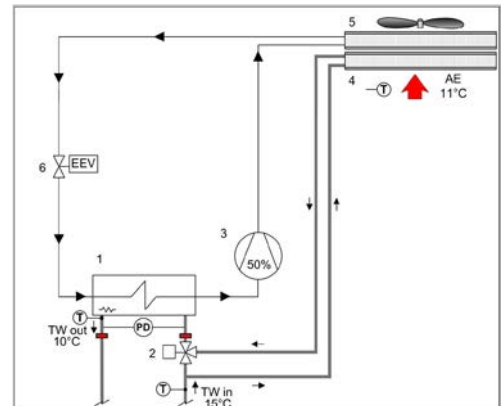
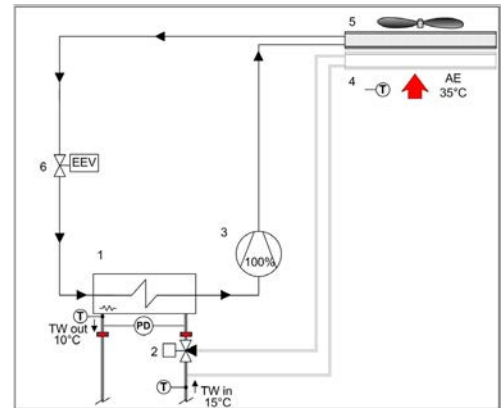

- |                                      |                                |                                   |
|--------------------------------------|--------------------------------|-----------------------------------|
| 1 - Internal exchanger               | 5 - External fan               | TW in chilled water inlet         |
| 2 - Three-way valve for FREE-COOLING | 6 - Expansion electronic valve | TW out chilled water outlet       |
| 3 - Compressors                      | T - Temperature probe          | AE Outdoor air                    |
| 4 - External exchanger               |                                | PD - Differential pressure switch |



Check availability and compatibility of 'FCD - Direct FREE-COOLING' with the other accessories in the "Option compatibility" table

## Determination of chiller performance with direct FREE-COOLING in conditions of FC = ON

Size			2.160	2.180	2.190	2.200	2.240	2.280	2.300	2.320	2.340	2.360	2.440	2.480	2.540	2.600
SC	FREE-COOLING (1) rated power	kW	520	557	579	624	685	746	825	900	961	1049	1164	1311	1409	1523
	Air temperature with FREE-COOLING at 100% (1)	°C	-1,2	-1,9	0,7	0,0	-1,0	0,4	-0,7	-1,5	-2,2	-1,2	-2,3	-0,5	-1,4	-2,3
EN	FREE-COOLING (1) rated power	kW	516	550	578	624	680	745	819	894	938	1031	1132	1262	-	-
	Air temperature with FREE-COOLING at 100% (1)	°C	1,6	1,2	0,7	2,1	1,3	-0,1	0,9	0,2	-0,2	1,7	0,9	-0,1	-	-

(1) Data refer to the following conditions:  
 - water temperature: 15°C inlet / 10°C outlet  
 - glycol percentage 30%

### Determination of the direct FREE-COOLING percentage - SC configuration

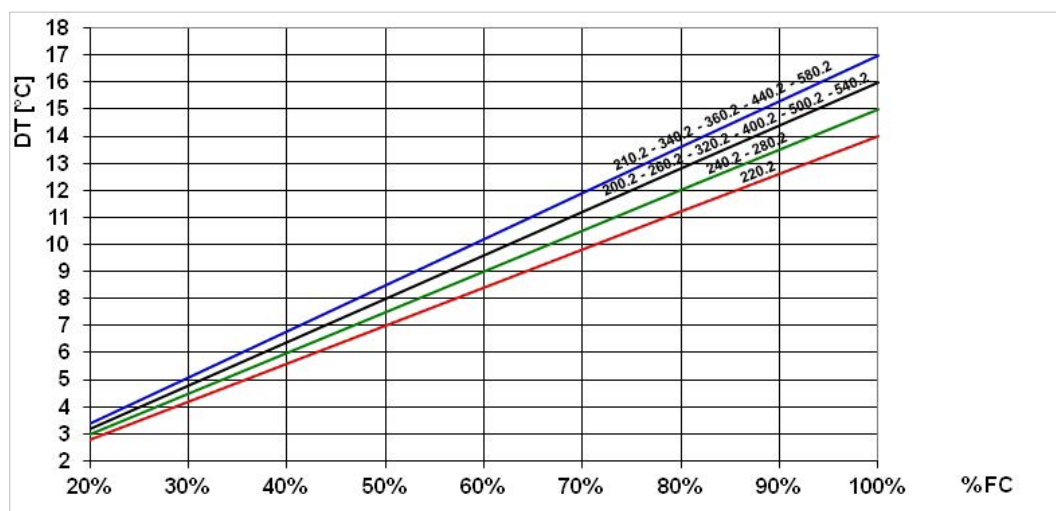

### Determination of the direct FREE-COOLING percentage - EN configuration

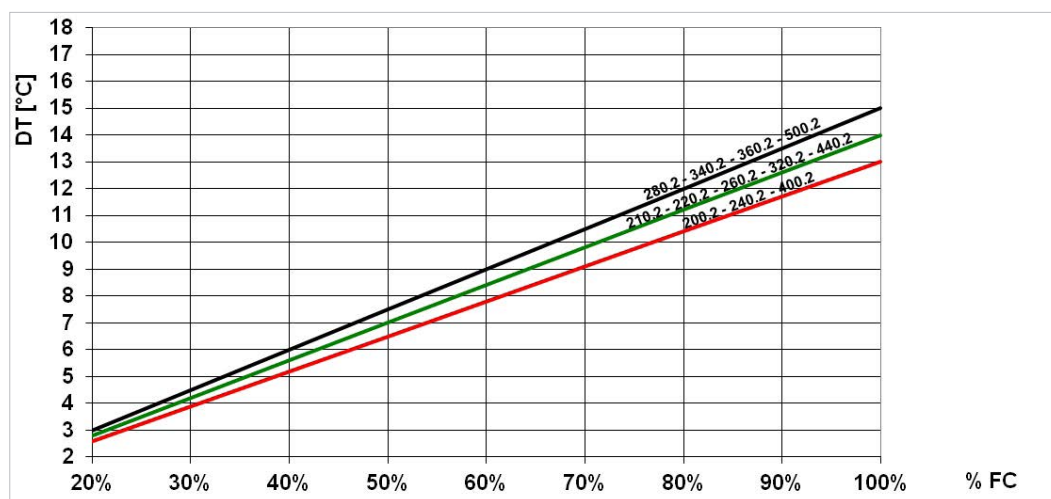

KEY  
 DT = Temperature difference between the system return water and the outdoor air  
 %FC = FREE-COOLING percentage (in relation to the rated FREE-COOLING capacity)

Example: Determine the performances with outdoor air = +1°C for the following unit: WDAT-SL3 200.2 FCD EXC SC (EXCELLENCE version, direct FREE-COOLING configuration), with water 15/10 °C / 30% glycol.

Reference: WDAT-SL3 200.2 FCD EXC SC: FREE-COOLING rated power = 520 kW (from table with water 15/10 °C / 30% glycol/ outdoor air temperature -1,2°C).

Calculation: Difference between the installation return water and the outdoor air = 15°C - 1°C = 14°C

The graph shows that: FREE-COOLING percentage = 87%; direct FREE-COOLING capacity at +1°C outdoors = 520 x 87% = 452 kW

## FCI - No-glycol FREE-COOLING

Configuration that allows for considerable savings on the system's running costs in applications that require chilled water also during the cold season, such as industrial processes, data centres, telecommunications, technological applications and shopping centres. Does not require the addition of an antifreeze substance in the hydraulic circuit used. Therefore, it is particularly suitable for large-sized systems and wherever laws and regulations limit the use of antifreeze substances inside buildings. Moreover, it does not affect the performance of terminal units and the system's pumping units. When the outdoor air temperature is lower than the temperature of the system's return water, the FREE-COOLING system recovers cold from the external environment and reduces the operation of the compressors until they stop completely. The higher the temperature of the chilled water in the system (e.g. 10-15°C instead of 7-12°C), the greater the operating range of the FREE-COOLING system and, therefore, the higher the energy savings.

### Management logic

There are three main operating modes, which basically differ in terms of activation of the FREE-COOLING circuit electric pump and the number of active compressors:

#### (A) Summer

In the summer season, with outdoor air temperatures which are greater than the return temperature of the liquid in the system, the electric pump is off and the fluid circulation by the FREE-COOLING coils is not present. The cooling of the liquid is referred to the direct expansion circuit, with the intervention of the compressors as in a traditional chiller.

#### (B) Intermediate season

In the winter season, or rather with the outdoor air temperature at a little below the return water temperature of the system, when the unit identifies that the temperature conditions are favourable:

- activates the electric pump of the free-cooling circuit by creating an exchange of energy between the liquid in the system and the free-cooling circuit before reaching the evaporator
- brings the fans to maximum speed to make the most of the cooling of the solution carried out by the outdoor air
- conducts a first cooling of the solution in a 'natural way and free of charge'
- provides any missing capacity via the cooling circuit using compressors with partial operation (power input proportional to the partialisation level)

If the outdoor air temperature should increase, the microprocessor automatically converts the operating mode to the summer mode, guaranteeing the conditions requested by the user at all times.

#### (C) Winter

In the winter season, with the outdoor air temperature below the return water temperature of the system, the unit identifies that the temperature conditions are favourable for operating in FREE-COOLING mode:

- as in the previous scenario, it activates the electric pump on the free-cooling circuit by creating an exchange of energy between the liquid in the system and the free-cooling circuit before reaching the evaporator
- acts on the speed of the fans until it turns them off in order to reach the temperature required on the system's supply line
- the microprocessor control turns off all the compressors by releasing all the desired cooling capacity AT ZERO COST, unlike traditional chillers

If the temperature keeps dropping with all the fans off, the electric pump turns off, which allows the desired set point value to be maintained.

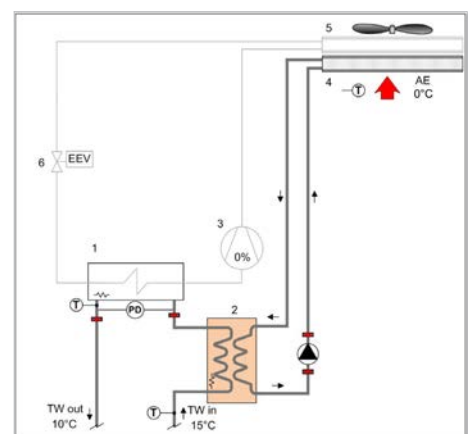
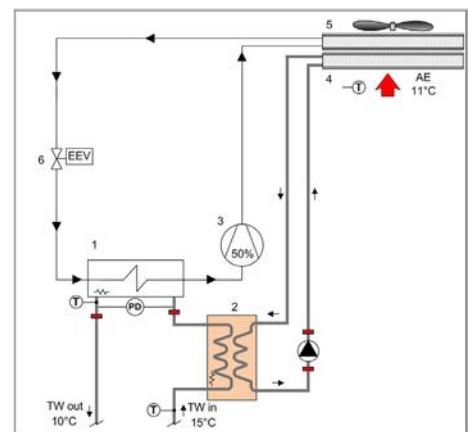
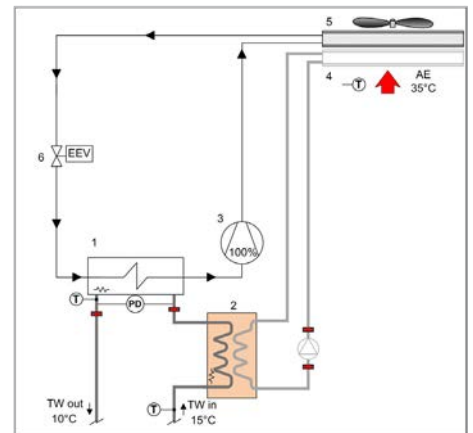

- |  |                                   |                                   |
|--|-----------------------------------|-----------------------------------|
| 1 - Internal exchanger                 | 5 - External fan                  | TW in chilled water inlet         |
| 2 - Water-water intermediate exchanger | 6 - Expansion electronic valve    | TW out chilled water outlet       |
| 3 - Compressors                        | T - Temperature probe             | AE Outdoor air                    |
| 4 - External exchanger                 | PD - Differential pressure switch | PD - Differential pressure switch |



Check availability and compatibility of 'FCI - No-glycol FREE-COOLING' with the other accessories in the "Option compatibility" table

## Determination of chiller performance with no-glycol FREE-COOLING in conditions of FC = ON

Size			200.2	210.2	220.2	240.2	260.2	280.2	320.2	340.2	360.2	400.2	440.2	500.2	540.2	580.2
SC	FREE-COOLING (1) rated power	kW	539	578	601	648	711	774	856	934	997	1089	1208	1360	1462	1580
	Air temperature with FREE-COOLING at 100% (1)	°C	-2,8	-3,7	-1,2	-2,0	-3,2	-1,9	-3,0	-2,8	-3,6	-2,8	-4,2	-2,6	-3,5	-4,6
EN	FREE-COOLING (1) rated power	kW	535	570	599	647	706	773	850	928	974	1070	1175	1309	-	-
	Air temperature with FREE-COOLING at 100% (1)	°C	-0,2	-0,7	-1,2	-0,1	-0,8	-0,9	-0,3	-1,2	-1,6	-0,1	-1,1	-2,1	-	-

(1) Data refer to the following conditions:  
 - water temperature: 15°C inlet / 10°C outlet

### Determination of the no-glycol FREE-COOLING percentage - SC configuration

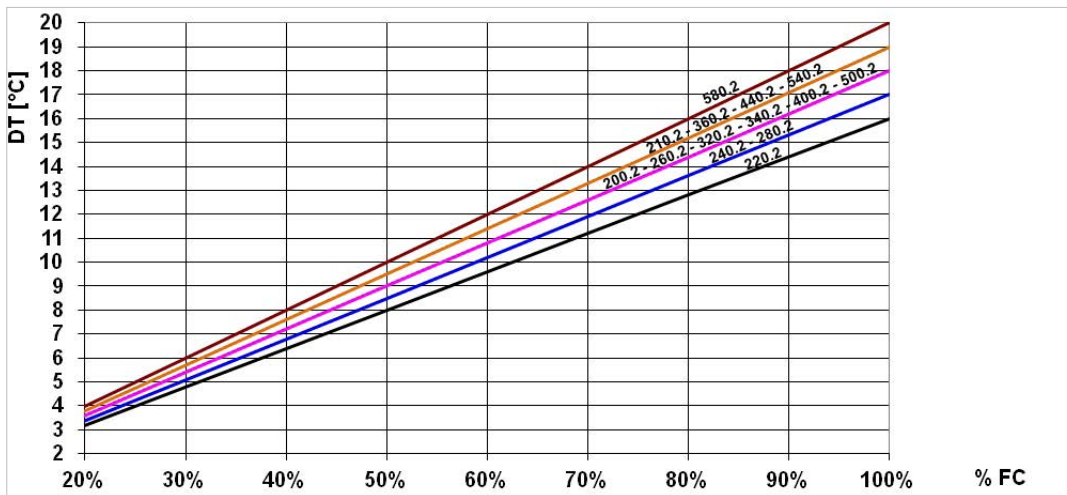

### Determination of the no-glycol FREE-COOLING percentage - EN configuration

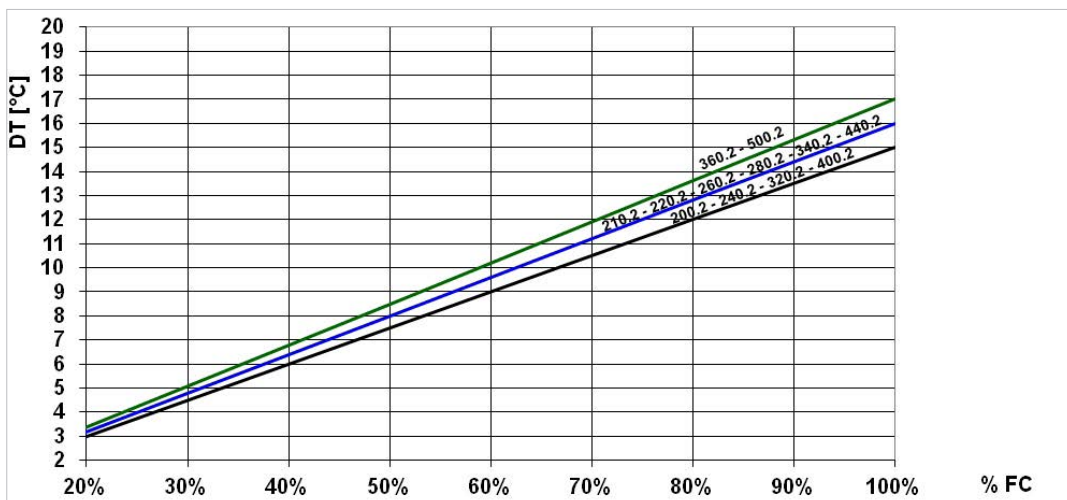

KEY  
 DT = Temperature difference between the system return water and the outdoor air  
 %FC = FREE-COOLING percentage (in relation to the rated FREE-COOLING capacity)

Example: Determine the performances with outdoor air = +1°C for the following unit: WDAT-SL3 200.2 FCI EXC SC (EXCELLENCE version, No-glycol FREE-COOLING configuration), with water at 15/10 °C.

Reference: WDAT-SL3 200.2 FCI EXC SC: FREE-COOLING rated power = 539 kW (from table with water 15/10 °C / outdoor air temperature -2,8°C).

Calculation: Difference between the installation return water and the outdoor air = 15°C - 1°C = 14°C

The graph shows that: FREE-COOLING percentage = 78% : FREE-COOLING capacity at +1°C outdoors = 539 x 78% = 420 kW

## WOGLY - Unit supplied without glycol solution

The standard unit is supplied with antifreeze solution in the FREE-COOLING separated circuit. With WOGLY option the unit is supplied without antifreeze solution with the advantage of a reduction of shipping weight of 10% as well as a saving on the initial investment.



The antifreeze solution supply and charge are provided by the Customer. Refer to the Installation and Operating manual for the charging procedures.



For the water + glycol solution content, refer to the 'Quantity of glycol in the no-glycol FREE-COOLING' table.

**Option valid in combination with 'FCI - no-glycol FREE-COOLING'.**

### Quantity of glycol in the no-glycol FREE-COOLING

Size		200.2	210.2	220.2	240.2	260.2	280.2	320.2	340.2	360.2	400.2	440.2	500.2	540.2	580.2	
SC	Water solution total volume + glycol	l	443	445	526	530	536	646	653	929	939	1080	1092	1062	1082	1092
	Freezing temperature	°C	-15.6													
	Ethylene glycol volume (30%)	l	133	134	158	159	161	194	196	279	282	324	328	319	325	328
	Glycol solution total weight (30%)	kg	459	461	545	549	555	669	677	963	973	1119	1132	1100	1121	1132
	Freezing temperature	°C	-23.4													
	Ethylene glycol volume (40%)	l	177	178	210	212	214	258	261	372	376	432	437	425	433	437
	Glycol solution total weight (40%)	kg	464	466	551	556	562	677	685	974	984	1132	1145	1113	1134	1145
	Freezing temperature	°C	-33.0													
	Ethylene glycol volume (50%)	l	222	223	263	265	268	323	327	465	470	540	546	531	541	546
	Glycol solution total weight (50%)	kg	470	472	558	562	568	685	692	985	996	1145	1158	1126	1147	1158
	Freezing temperature	°C	-39.0													
	Ethylene glycol volume (60%)	l	266	267	316	318	322	388	392	557	563	648	655	637	649	655
Glycol solution total weight (60%)	kg	475	477	564	568	575	693	700	996	1007	1158	1171	1139	1160	1171	

Size		200.2	210.2	220.2	240.2	260.2	280.2	320.2	340.2	360.2	400.2	440.2	500.2	
EN	Water solution total volume + glycol	l	520	522	526	616	622	877	948	993	1003	1030	1042	1062
	Freezing temperature	°C	-15.6											
	Ethylene glycol volume (30%)	l	156	157	158	185	187	263	284	298	301	309	313	319
	Glycol solution total weight (30%)	kg	539	541	545	638	645	909	982	1029	1039	1067	1080	1100
	Freezing temperature	°C	-23.4											
	Ethylene glycol volume (40%)	l	208	209	210	246	249	351	379	397	401	412	417	425
	Glycol solution total weight (40%)	kg	545	547	551	646	652	919	994	1041	1051	1080	1092	1113
	Freezing temperature	°C	-33.0											
	Ethylene glycol volume (50%)	l	260	261	263	308	311	439	474	497	502	515	521	531
	Glycol solution total weight (50%)	kg	551	477	558	567	574	699	710	989	1000	1142	1155	1126
	Freezing temperature	°C	-39.0											
	Ethylene glycol volume (60%)	l	312	313	316	370	373	526	569	596	602	618	625	637
Glycol solution total weight (60%)	kg	558	560	564	661	667	941	1017	1065	1076	1105	1117	1139	



# Configurations

## EN - Super-silenced configuration

Configuration used to increase the unit's silent operation by acting on the source of the noise. It consists of suitable steel casings lined with high-density material designed to provide sound insulation. The casings are secured to an aluminium frame and painted on the outside with polyester powder (RAL 9001).

Fans at low RPM.

To assess the quality of the soundproofing benefit, refer to the 'Sound levels' tables.

## B - Water low temperature (Brine)

Configuration also known as "Brine". Enables an "unfreezable" solution to be cooled (for example, water and ethylene glycol in suitable quantities) up to a temperature of between +4°C and -8°C. It includes:

- suitable exchangers with extra-thick closed-cell insulation
- electronic expansion valve, functional calibration and safety devices suitable for particular uses.

During the selection phase it is necessary to indicate the required operating type, the unit will be optimised on the basis of this: - Unit with single operating set-point (only at low temperature) - Unit with double operating set-point.

The unit in this configuration has a different operating field, which was reported in the previous pages.

In low temperature operation, some staging steps could not be available.

The glycol concentration must be chosen based on the minimum temperature the water can reach. The presence of glycol influences pressure drops on the water side and the unit's output as indicated in the table reporting the "correction factors for use with glycol".

### Correction factor for water low temperature

Evaporator outlet water temperature factor	2	0	-2	-4
Cooling capacity factor	0.860	0.804	0.748	0.692
Compressor power input factor	0.945	0.923	0.901	0.879

The correction coefficients must be applied to condition: internal exchanger water (evaporator) = 12 / 7 °C.

**Example:** Determine the performance with leaving water temperature -4°C for WDAT-SL3 FC 200.2 EXC SC B (Excellence' version, 'Water low temperature' acoustic configuration : compressor soundproofing' configuration) with external exchanger water (condenser) 35°C, 30% glycol.

From the performance table referred to entering external exchanger water temperature (condenser) 35 °C and leaving internal exchanger water temperature (evaporator) 7°C:

Cooling capacity = 469 kW, Compressor power input = 137 kW

From the correction factor table for water low temperature: 0.692 for cooling capacity and 0.879 for compressor power input (supply water temperature -4°C)

From the glycol correction factor: 0.964 for cooling capacity, 1.007 for compressor power input, 1.072 the glycol solution flow, 1.3 for the evaporator pressure drop (glycol 30%)

Calculation WDAT-SL3 FC 200.2 EXC SC B: Cooling capacity = 469 x 0.692 x 0.964 = 313 kW, Compressor power input = 137 x 0.879 x 1.007 = 121 kW

Water flow-rate = 15 (calculated on 313 kW) x 1.072 = 16 l/s, Evaporator pressure drop = 26.6 (calculated on 15 l/s) x 1.3 = 34.6 kPa

## D - Partial energy recovery

A configuration which enables the production of hot water free-of-charge while operating in the cooling mode, thanks to the partial recovery of condensation heat that would otherwise be rejected to the external heat source. This option is also called 'desuperheater'. It consists of shell and tube heat exchangers, suitable to recover part of the unit heating capacity (equal to the sum of the cooling capacity and the capacity absorbed by the compressors).

The partial recovery device is considered to be operating when it is powered by the water flow which is to be heated. This condition improves the unit performance, since it reduces the condensation temperature: in nominal conditions the cooling capacity increases indicatively by 3.2% and the power input of the compressors is reduced by 3.6%.

When the temperature of the water to be heated is particularly low, it is wise to insert a flow control valve into the system water circuit, in order to maintain the temperature at the recovery output at above 35°C and thus avoid the condensation of the refrigerant into the partial energy recovery device.

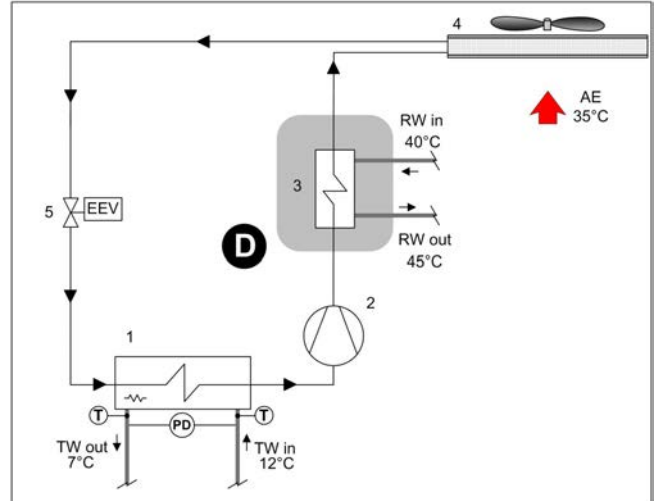

**D - Partial recovery device**

- 1 - Internal exchanger
- 2 - Compressors
- 3 - Recovery exchanger
- 4 - External exchanger
- 5 - Expansion electronic valve

TW in chilled water inlet  
TW out chilled water outlet

RW in - Recovery water inlet  
RW out - Recovery water outlet

T - Temperature probe  
PD - Differential pressure switch  
AE Outdoor air



The maximum capacity available from the partial recovery is equal to the 15% of the rejected heating capacity (cooling capacity + compressor power input)

### Pressure drops of partial energy recovery exchanger

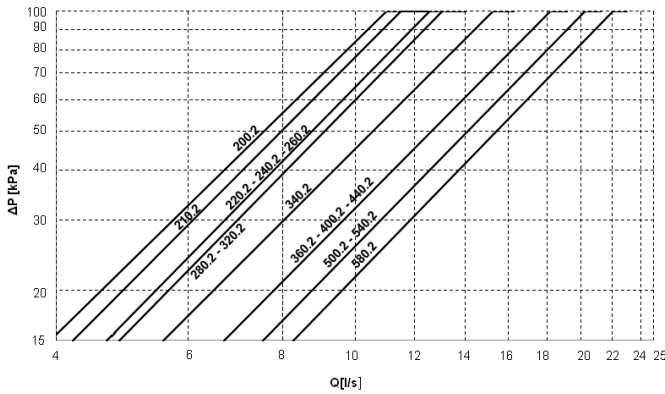

Q = water flow-rate[l/s]  
DP = water side pressure drops (kPa)

**Example:** Required cooling capacity: 500 kW at 12/7°C chilled water and 35°C outdoor air.

Size purpose of the study: WDAT-SL3 FC 210.2 EXC SC

Hot water required temperature: +45°C

Recovery capacity: 19% di 500 kW = 95 kW

Design flow-rate: 4,5 l/s

Recovery pressure drop: 17,5 kPa

### Partial recovery heating capacity

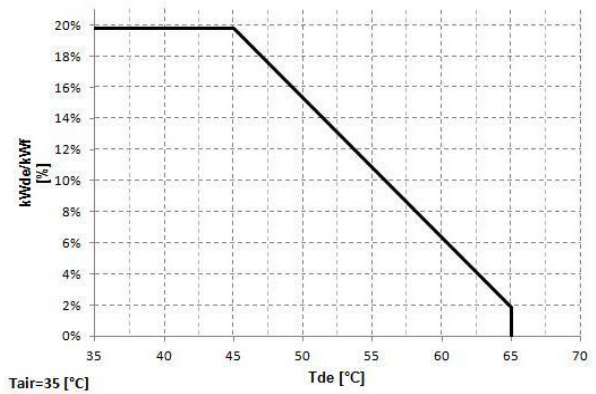

kWde/kWf = Heat recovered/Cooling capacity [%]  
Tde = Heat recovering device outlet water temperature [°C]



Data refer to outdoor air conditions T=35°C

## Application of the partial / total energy recovery

In almost all systems fitted with a chiller used to produce chilled water there is also the need to have hot water. The recovery of condensation heat is an efficient way of producing hot water while the chiller is in operation. It has the double benefit of both reducing the heat load to the condenser, thereby eliminating dissipation costs and generating free hot water, thereby reducing the costs of the auxiliary heater.

### Application versatility of recovery devices

The hot water produced by heat recovery can be used in a number of ways: to reheat air in handling units, to preheat hot water for domestic use or industrial processes, to heat up water in swimming pools, showers and spas, to preheat hot water for laundries or industrial kitchens.



Post-heating in air handling units to control humidity levels in hospitals and labs



Preheating of hot water for domestic use or for industrial process



Heating of water in swimming pools, showers and SPAS



Preheating of hot water for laundries and industrial kitchens

### Water heating up

The heat recovery device can be used to cover the entire heat load required. The hot water supply temperature is controlled via a modulating control valve that needs to be fitted on the system at the outlet of the recovery unit. The auxiliary heating device is recommended to cover the thermal energy demand when the chiller is not in operation or is operating at part load.

Example of how heat recovery is used to cover the entire heat demand and control the operating temperature

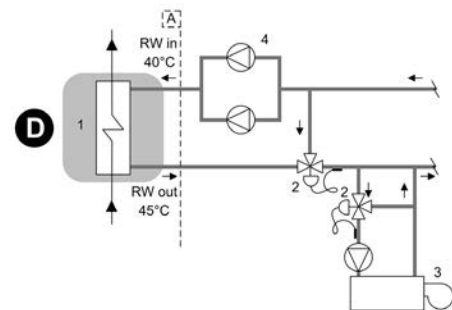

### Water preheating

The heat recovery device can be used to preheat water at the inlet of the main heating device (e.g. boiler). In this case, the demand for hot water is greater than the amount of heat recovered by condensation and the recovery device only covers part of the required heat load. By preheating the water, heating consumption levels are therefore reduced and the main heating device has a lower installed power requirement.

Example of how heat recovery is used to preheat hot water in the system

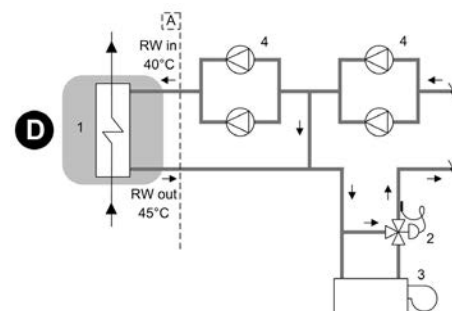

### Domestic hot water production

The heat recovery device can be used to produce water for domestic use. In order to prevent contamination of domestic water with the chiller's process fluid, it is necessary to insert an intermediate heat exchanger. Using an inertial heat storage tank allows to have a reserve of preheated water and enables the intermediate exchanger to operate more efficiently.

Example of how heat recovery is used to preheat hot water for domestic use

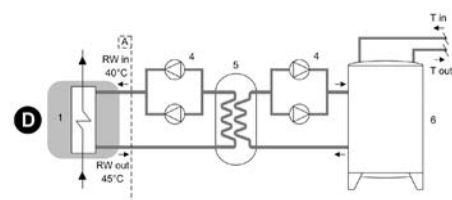

- A - Unit supply limit
- 1 - Recovery exchanger
- 3 - Auxiliary heating device (ex.boiler)
- 5 - Intermediate heat exchanger
- RW in - Recovery water inlet
- T in - Drinkable water inlet

- D - Partial energy recovery
- 2 - Control modulating valve
- 4 - Electric pump with standby pump
- 6 - Inertial heat storage
- RW out - Recovery water outlet
- T out - Drinkable water outlet to the auxiliary heater

The diagrams refer to partial energy recovery, though they also apply to total energy recovery (Clivet R). Please note that the diagrams are only meant as a guide.

# Accessories - Hydronic assembly

## 2PM/3PM - HydroPack with no.2/3 pumps

Option supplied built-in the unit. Pumping unit made up of two or three electric pumps laid out in parallel, with auto-adaptive modular logic activation.

It enables the automatic reduction of the liquid flow-rate in critical conditions, avoiding blocks due to overloading and consequential intervention work by specialised technical personnel.

Centrifugal electric pump, with the pump body made of cast iron and the impeller made of AISI 316 stainless steel.

Mechanical seal using ceramic, carbon and EPDM elastomer components.

Three-phase electric motor with IP55 degree of protection. Complete with a thermoformed insulating casing, quick connections with insulated casing, non-return valve, safety valve, pressure gauges, system safety pressure switch, stainless steel antifreeze, intake, immersion-type heaters.

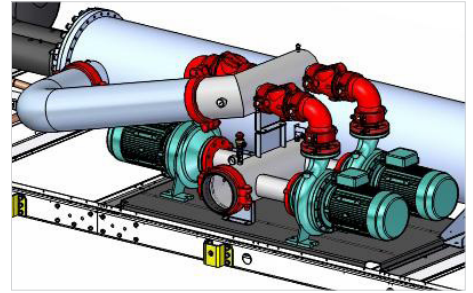

In order to increase the unit's silent operation, as an alternative to electric pumps with a 2-pole motor (2950 rpm), there are also electric pumps with 4-pole motors (1450 rpm), subject to a check regarding the maximum available pressure. The super-silent acoustic configuration (EN) only comes with electric pumps fitted with 4-pole motors.

CONNECTION DIAGRAM - GROUP WITH 2 PUMPS

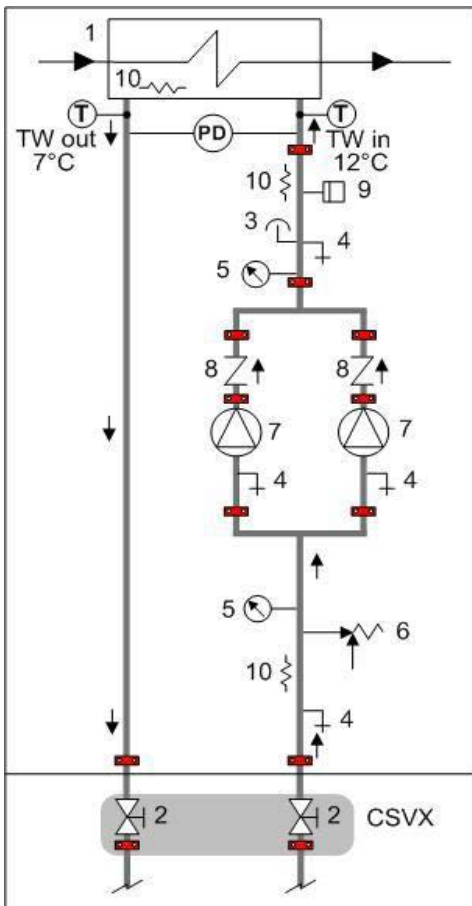

CONNECTION DIAGRAM - GROUP WITH 3 PUMPS

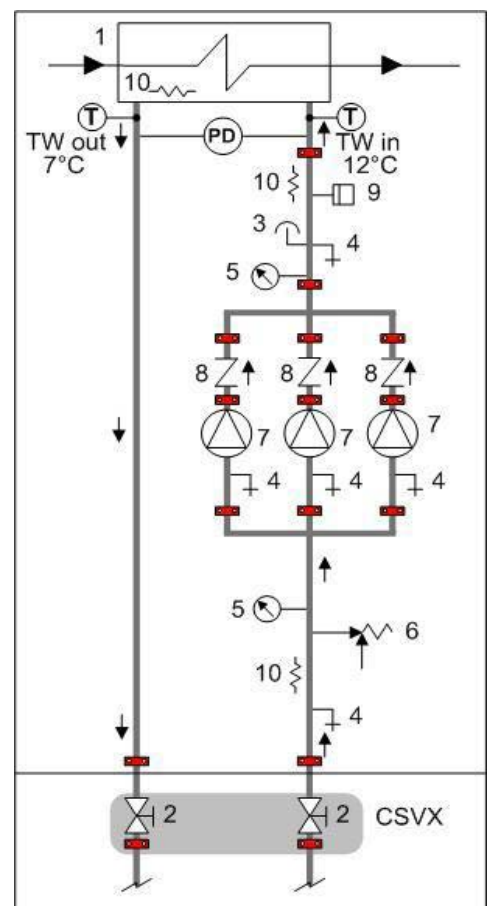

- 1 - Internal exchanger
- 2 - Cutoff valve
- 3 - Purge valve
- 4 - Discharge stop valve
- 5 - Pressure gauge
- 6 - Safety valve (6 Bar)
- 7 - Packaged electric pump with high efficiency impeller

- 8 - Non return valve
- 9 - System load safety pressure switch (it avoids the pump operation if water is not present)
- 10 - Antifreeze heater
- T - Temperature probe
- PD - Differential pressure switch

TW in chilled water inlet  
TW out chilled water outlet

CSVX - Couple of manually operated shut-off valves

**The grey area indicates further optional components.**



Provide hydraulic interceptions outside the unit ('CSVX - Couple of manually operated shut-off valves' option) to facilitate any possible extraordinary maintenance interventions.

## 2PM / 3PM option performances (electric pump with 2-pole motor)

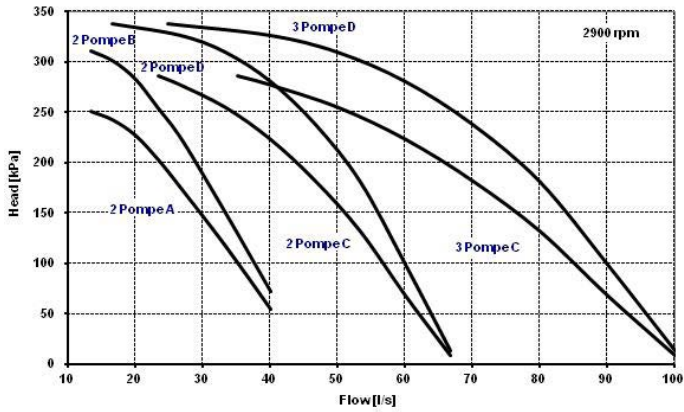

Attention: the evaporator pressure drops have to be taken from the heads represented in these diagrams in order to obtain the available head values.



Not available with unit in Super-silenced configuration (EN)



Check availability of the different type of pump with size in the 'Option compatibility' table.

## 2PM / 3PM option performances (electric pump with 4-pole motor)

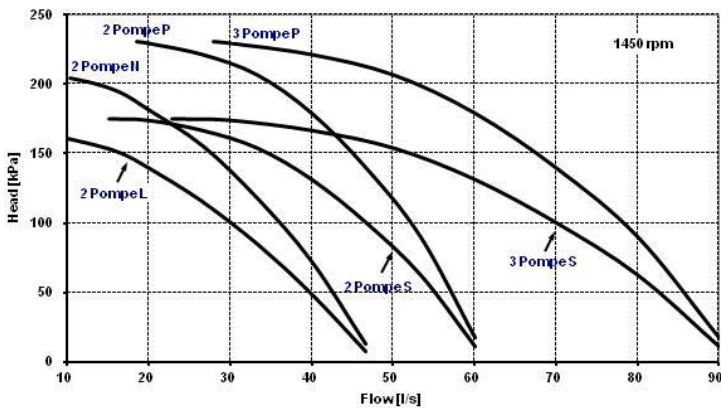

Attention: the evaporator pressure drops have to be taken from the heads represented in these diagrams in order to obtain the available head values.



Check availability of the different type of pump with size in the 'Option compatibility' table.



To the internal exchanger pressure drops must be added the pressure drops of the steel mesh mechanical filter (not supplied) that must be placed on the water input line. It is a device compulsory for the correct unit operation and it must be selected and installed by the Customer. It is forbidden the use of filters with the mesh pitch higher than 1,0 mm. Filters with higher mesh pitch can cause a bad unit operation and also its serious damaging.

## Electrical data - HydroPack

To obtain the electrical consumption of the unit including the Hydropack accessory, the electrical data of the selected accessory are added to the standard electrical data indicated in the Electrical Data table.

HydroPack				
n° Pumps	Type	[kW]	[A]	
2	A	8	17,4	
2	B	11	20,8	
2	C	15	27,2	
2	D	22	40,4	
2	L	8	16	
2	N	11	20,6	
2	P	22	41,4	
2	S	11	20,6	
3	C	22,5	40,8	
3	D	33	60,6	
3	P	33	62,1	
3	S	16,5	30,9	

## Accessories

### PGCC - Condensing coil protection grilles and technical compartment

This accessory is used to protect the external coil from the accidental contact with external things or people.

Ideal for installation in places where persons can pass from, such as car parks, terraces, etc.

The accessory is provided and installed built-in the unit.



This option is not suitable for application in sulphuric environments.

### PGCCH - Condensing coil anti-hail protection grilles

These accessories are to protect the external coil from hail damage. Indeed, hail impact can deform the coil fins worsening the heat exchange with the air.

The accessory is provided and installed built-in the unit.

### CCCA - Copper / aluminium condensing coil with acrylic lining

Coils with copper pipes and aluminium fins with acrylic lacquering. Can be used in settings with moderately aggressive low saline concentrations and other chemical agents.

Attention!

- cooling capacity variation -2.7%
- variation in compressor power input +4.2%
- operating range reduction -2.1°C

### CCCA1 - Copper / aluminium condensing coil with Aluminium Energy Guard DCC treatment

A treatment which offers an optimal thermal exchange and guarantees and protects the finned coil exchangers from corrosion over time. Can be used in settings with very aggressive saline concentrations and other chemical agents in the air thus maintaining the performance of the coils over time.

### CCCC - Copper / copper condensing coil

Coils with copper pipes, copper fins and brass structure. Can be used in settings with moderately aggressive saline concentrations and other chemical agents.



This option is not suitable for application in sulphuric environments



Option available on request

### CREFB - ECOBREEZE external section fan consumption reduction device

An option which regards the external helical fans, as an alternative to the phase-cut device which is supplied as standard in ST and SC versions. It provides for an IP54 brushless electronically commutated electrical motor and incorporated thermal protection. Supplied with variable speed control. Standard for EN version.

### PFCP - Power-factor correction capacitors (cosφ > 0.9)

The component is necessary to lower the phase difference between current and voltage in the electromagnetic components of the unit (e.g. asynchronous motors). The component allows to put the cosφ power factor to values on average higher than 0.9, reducing the network reactive power. This often leads to an economic benefit which the energy provider grants to the final user.

The device is installed and wired built-in the unit.

## CMSC9 - Serial communication module for Modbus supervisor

This enables the serial connection of the supervision system, using Modbus as the communication protocol. It enables access to the complete list of operational variables, commands and alarms. Using this accessory every unit can dialogue with the main supervision systems.

The device is installed and wired built-in the unit.



The total length of each serial line do not exceed 1000 meters and the line must be connected in bus typology (in/out)

## CMSC10 - Serial communication module for LonWorks supervisor

This enables the serial connection of the supervision system which uses the LonWorks communication protocol. It enables access to a list of operating variables, commands and alarms which comply with the Echelon® standard.

The device is installed and wired built-in the unit.



The configuration and management activities for the LonWorks networks are the responsibility of the client.



LonWorks technology uses the LonTalk® protocol for communicating between the network nodes. Contact the service supplier for further information.



The total length of each serial line do not exceed 1000 meters and the line must be connected in bus typology (in/out)

## CMSC11 - Serial communication module for BACnet-IP supervisor

Allows the serial connection to supervision systems by using BACnet-IP as a communication protocol. It allows the access to the entire list of operating variables, controls and alarms. With this accessory every unit can communicate with the main supervision systems.

The device is installed and wired built-in the unit.



The configuration and management activities for the BACnet networks are the responsibility of the client.



The total length of each serial line do not exceed 1000 meters and the line must be connected in bus typology (in/out)

## ECS - ECOSHARE function for the automatic management of a group of units

The device allows automatic management of units that operate on the same hydraulic circuit, by creating a local communication network.

There are two control modes that can be set via a parameter during the activation stage. They both distribute the heat load on the available units by following the distribution logic to benefit from efficiency levels at part load.

Moreover:

Mode 1 - it keeps all the pumps active

Mode 2 - it activates only the pumps of the unit required to operate

The device allows for rotation based on the criterion of minimum wear and management of units in stand-by. There are various unit sizes. Every unit must be fitted with the ECOSHARE feature. The set of units is controlled by a Master unit.

The local network can be extended up to 7 units (1 Master and 6 Slave).



The unit supplied with this device can also be equipped at the same time with the RCMRX option and one of the CMSC9 / CMSC10 / CMSC11 options.

## CBS - Compressor magnetothermic circuit breakers

The magnetothermic circuit breakers are inserted instead of the fuses for the protection against the short circuit and overload. In case of intervention they do not have to be replaced, as it happens with fuses.

## SFSTR2 - Progressive compressor start-up device

This option is also called 'Soft starter'. Electronic device that automatically and gradually starts the compressors, thereby reducing the current peak generated in star-triangle start-ups and therefore reduces the mechanical stress on the motor and the electrodynamic stress on the power cables and on the mains.

The device is installed and wired built-in the unit.

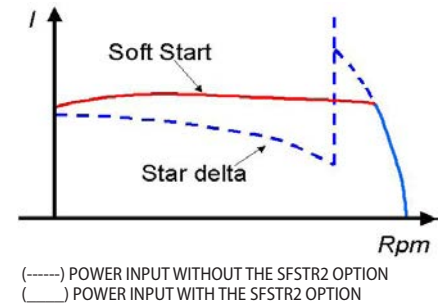

## CONTA2 - Energy meter

Allows to display and record the unit's main electrical parameters. The data can be displayed with the user interface on the unit or via the supervisor through the specific protocol variables.

It is possible to control:

- voltage (V),
- absorbed current (A),
- frequency (Hz),
- cosφ,
- power input (kW),
- absorbed energy (kWh),
- harmonic components (%).

The device is installed and wired built-in the unit.



Only the following parameters are available on the LonWorks protocol: power input (kW) and absorbed energy (kWh)

## SCP4 - Set point compensation with 0-10 V signal

This device enables the set-point to be varied which is pre-set using an external 0÷10 V signal.

The device is installed and wired built-in the unit.



## SPC1 - Set point compensation with 4-20mA signal

This device enables the set-point to be varied which is pre-set using an external 4-20mA signal.

The device is installed and wired built-in the unit.

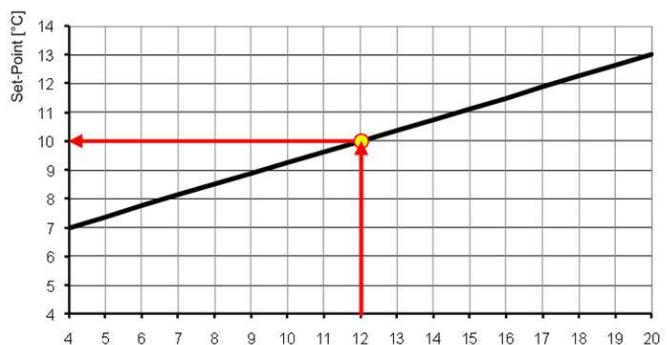



## SPC2 - Set-point compensation with outdoor air temperature probe

This device enables the set-point to be varied automatically which is pre-set depending on the outdoor air temperature. This device enables the liquid flow temperature to be obtained, which varies depending on external conditions, enabling energy savings throughout the entire system.

The device is installed and wired built-in the unit.

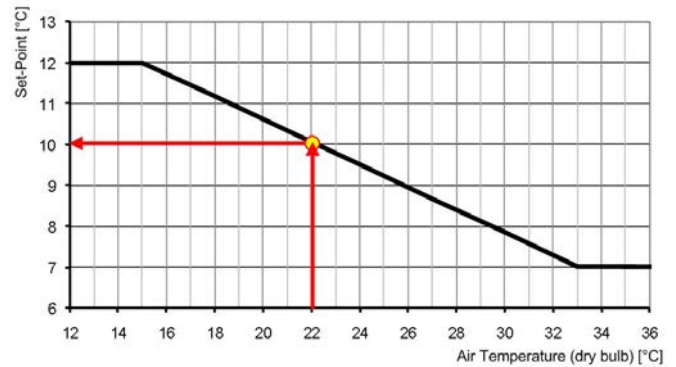

The device includes a probe controlled remotely from outside to measure the outdoor air temperature. (installation to be carried out by the customer). The connection cable length is 16 m.

## RE-20 / RE-25 / RE-30 / RE-35 / RE-39 - Electrical panel antifreeze protection

This option is necessary for very cold climates, where the external temperature can be between -10°C and -39°C. It includes self-regulating temperature maintaining resistances which are able to protect the electrical panel against condensation and frost guaranteeing that it functions correctly. The choice of device should be carried out on the basis of the minimum temperatures reached at the unit installation site.

The device is built-in the unit.



It is necessary to make precautions against build up of snow and ice in front of the exhaust and outdoor air inlet locations.



This accessory operates even when the unit is switched off provided that the power supply is maintained active and the unit continues to be connected.



This accessory does not lead to substantial variations in the electrical data for the unit which has been declared in the Electrical Data section.

## Accessories separately supplied

### RCMRX - Remote control via microprocessor remote control

This option allows to have full control over all the unit functions from a remote position. It can be easily installed on the wall and has the same aspect and functions of the user interface on the unit.



All device functions can be repeated with a normal portable PC connected to the unit with an Ethernet cable and equipped with an internet navigation browser.



The device must be installed on the wall with suitable plugs and connected to the unit (installation and wiring to be conducted by the Customer). Maximum remote control distance 350 m without auxiliary power supply. For distances greater than 350 m and in any case less than 700 m it is necessary to install the 'PSX - Mains power unit' accessory.



Data and power supply serial connection cable n.1 twisted and shielded pair. Diameter of the individual conductor 0.8 mm.



Installation provided by the Customer,

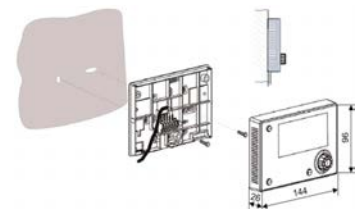

### PSX - Mains power supply unit

The device allows the unit and the remote control to communicate with the user interface even when the serial line is longer than 350m.

It must be connected to the serial line at a distance of 350m from the unit and allows to extend the length to 700m maximum in total. The device requires an external power supply at 230V AC.



Power supply at 230V AC provided by Customer

### AMMX - Spring antivibration mounts

The spring antivibration mounts are attached in special housing on the support frame and serve to smooth the vibrations produced by the unit thus reducing the noise transmitted to the support structure.

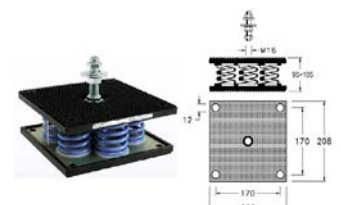

### CSVX - Couple of manually operated shut-off valves

The kit allows to isolated the input and output water circuit. It includes:

- n. 2 of cast-iron shut-off butterfly valves with fast fittings and activation lever with a mechanical setting lock
- no. 2 quick connections



Installation provided by the Customer, outside the unit.



## Option compatibility

REF.	DESCRIPTION	200.2	210.2	220.2	240.2	260.2	280.2	320.2	340.2	360.2	400.2	440.2	500.2	540.2	580.2
<b>CONFIGURATIONS AND MAIN ACCESSORIES</b>															
<b>B / D</b>	Water low temperature / Partial energy recovery	0	0	0	0	0	0	0	0	0	0	0	0	0	0
<b>B + D</b>	Water low temperature + Partial energy recovery	0	0	0	0	0	0	0	0	0	0	0	0	0	0
<b>B + FCD</b>	Water low temperature + Direct FREE-COOLING	0	0	0	0	0	0	0	0	0	0	0	0	0	0
<b>B + FCI</b>	Water low temperature + No-glycol FREE-COOLING	X	X	X	X	X	X	X	X	X	X	X	X	X	X
<b>D + FCD</b>	Partial energy recovery + Direct FREE-COOLING	0	0	0	0	0	0	0	0	0	0	0	0	0	0
<b>D + FCI + SC</b>	Partial energy recovery + No-glycol FREE-COOLING + Acoustic configuration with compressor soundproofing	X	X	X	X	X	X	X	0	0	0	0	0	0	0
<b>D + FCI + EN</b>	Partial energy recovery + No-glycol FREE-COOLING + Super-silenced acoustic configuration	X	X	X	X	X	0	0	0	0	0	0	0	X	X
<b>B + D + FCD</b>	Water low temperature + Partial energy recovery + Direct FREE-COOLING	0	0	0	0	0	0	0	0	0	0	0	0	0	0
<b>B + D + FCI</b>	Water low temperature + Partial energy recovery + No-glycol FREE-COOLING	X	X	X	X	X	X	X	X	X	X	X	X	X	X
<b>2PM - HYDROPACK WITH NO.2 PUMPS</b>															
<b>D + FCD</b>	Partial energy recovery + Direct FREE-COOLING	0	0	0	0	0	0	0	0	0	0	0	0	0	0
<b>D + FCI + SC</b>	Partial energy recovery + No-glycol FREE-COOLING + Acoustic configuration with compressor soundproofing	X	X	X	X	X	X	X	0	0	0	0	0	0	0
<b>D + FCI + EN</b>	Partial energy recovery + No-glycol FREE-COOLING + Super-silenced acoustic configuration	X	X	X	X	X	0	0	0	0	0	0	0	X	X
<b>PUA2 + SC</b>	2 poles type A pump + Acoustic configuration with compressor soundproofing	Δ	Δ	Δ	Δ	Δ	0	Δ	0	X	X	X	X	X	X
<b>PUB2 + SC</b>	2 poles type B pump + Acoustic configuration with compressor soundproofing	0	0	Δ	Δ	Δ	Δ	0	Δ	X	X	X	X	X	X
<b>PUC2 + SC</b>	2 poles type C pump + Acoustic configuration with compressor soundproofing	X	0	0	0	0	0	0	Δ	Δ	Δ	0	Δ	0	X
<b>PUD2 + SC</b>	2 poles type D pump + Acoustic configuration with compressor soundproofing	0	0	0	0	0	0	0	0	0	0	Δ	Δ	0	X
<b>PUL4 + SC</b>	4 poles type L pump + Acoustic configuration with compressor soundproofing	Δ	Δ	Δ	Δ	Δ	Δ	0	0	0	0	X	X	X	X
<b>PUN4 + SC</b>	4 poles type N pump + Acoustic configuration with compressor soundproofing	Δ	Δ	0	0	0	0	0	0	0	0	X	X	X	X
<b>PUP4 + SC</b>	4 poles type P pump + Acoustic configuration with compressor soundproofing	0	0	0	0	0	Δ	Δ	0	Δ	Δ	Δ	0	X	X
<b>PUS4 + SC</b>	4 poles type S pump + Acoustic configuration with compressor soundproofing	X	X	X	X	X	0	Δ	Δ	Δ	Δ	Δ	0	X	X
<b>PUA2 + EN</b>	2 poles type A pump + Super-silenced acoustic configuration	X	X	X	X	X	X	X	X	X	X	X	X	X	X
<b>PUB2 + EN</b>	2 poles type B pump + Super-silenced acoustic configuration	X	X	X	X	X	X	X	X	X	X	X	X	X	X
<b>PUC2 + EN</b>	2 poles type C pump + Super-silenced acoustic configuration	X	X	X	X	X	X	X	X	X	X	X	X	X	X
<b>PUD2 + EN</b>	2 poles type D pump + Super-silenced acoustic configuration	X	X	X	X	X	X	X	X	X	X	X	X	X	X
<b>PUL4 + EN</b>	4 poles type L pump + Super-silenced acoustic configuration	Δ	Δ	Δ	Δ	Δ	Δ	0	0	0	0	X	X	X	X
<b>PUN4 + EN</b>	4 poles type N pump + Super-silenced acoustic configuration	Δ	Δ	Δ	Δ	Δ	Δ	Δ	Δ	0	0	X	X	X	X
<b>PUP4 + EN</b>	4 poles type N pump + Super-silenced acoustic configuration	Δ	Δ	Δ	Δ	Δ	Δ	Δ	Δ	Δ	Δ	Δ	Δ	X	X
<b>PUS4 + EN</b>	4 poles type S pump + Super-silenced acoustic configuration	0	0	0	0	0	0	Δ	Δ	Δ	Δ	Δ	0	X	X

• = Standard

0 = Available option

X = Option not available

Δ = Recommended option (low-mid high head, wherever available)

REF.	DESCRIPTION	200.2	210.2	220.2	240.2	260.2	280.2	320.2	340.2	360.2	400.2	440.2	500.2	540.2	580.2
<b>3PM - HYDROPACK WITH NO.3 PUMPS</b>															
<b>D + FCD</b>	Partial energy recovery + Direct FREE-COOLING	0	0	0	0	0	0	0	0	0	0	0	0	0	0
<b>D + FCI + SC</b>	Partial energy recovery + No-glycol FREE-COOLING + Acoustic configuration with compressor soundproofing	X	X	X	X	X	X	X	0	0	0	0	0	0	0
<b>D + FCI + EN</b>	Partial energy recovery + No-glycol FREE-COOLING + Super-silenced acoustic configuration	X	X	X	X	X	0	0	0	0	0	0	0	X	X
<b>PUC2 + SC</b>	2 poles type C pump + Acoustic configuration with compressor soundproofing	X	X	X	X	X	X	X	X	X	X	0	Δ	Δ	0
<b>PUD2 + SC</b>	2 poles type D pump + Acoustic configuration with compressor soundproofing	X	X	X	X	X	X	X	X	X	X	0	0	0	Δ
<b>PUP4 + SC</b>	4 poles type P pump + Acoustic configuration with compressor soundproofing	X	X	X	X	X	X	X	X	X	X	0	0	Δ	Δ
<b>PUS4 + SC</b>	4 poles type S pump + Acoustic configuration with compressor soundproofing	X	X	X	X	X	X	X	X	X	X	0	0	Δ	Δ
<b>PUC2 + EN</b>	2 poles type C pump + Super-silenced acoustic configuration	X	X	X	X	X	X	X	X	X	X	X	X	X	X
<b>PUD2 + EN</b>	2 poles type D pump + Super-silenced acoustic configuration	X	X	X	X	X	X	X	X	X	X	X	X	X	X
<b>PUP4 + EN</b>	4 poles type P pump + Super-silenced acoustic configuration	X	X	X	X	X	X	X	X	Δ	Δ	Δ	Δ	X	X
<b>PUS4 + EN</b>	4 poles type S pump + Super-silenced acoustic configuration	X	X	X	X	X	X	X	X	0	0	0	Δ	X	X
<b>OTHER ACCESSORIES</b>															
<b>CREFP + SC</b>	Fan consumption reduction device of external section at variable speed (phase-cutting) + Acoustic configuration with compressor soundproofing	•	•	•	•	•	•	•	•	•	•	•	•	•	•
<b>CREFB + SC</b>	ECOBREEZE external section fan consumption reduction device + Acoustic configuration with compressor soundproofing	0	0	0	0	0	0	0	0	0	0	0	0	0	0
<b>CREFP + EN</b>	Fan consumption reduction device of external section at variable speed (phase-cutting) + Super-silenced acoustic configuration	0	0	0	0	0	0	0	0	0	0	0	0	X	X
<b>CREFB + EN</b>	ECOBREEZE external section fan consumption reduction device + Super-silenced acoustic configuration	•	•	•	•	•	•	•	•	•	•	•	•	X	X

• = Standard

0 = Available option

X = Option not available

Δ = Recommended option (low-mid high head, wherever available)

# Dimensional drawings - FCD configuration (Direct FREE-COOLING)

## Size 200.2-210.2 - Acoustic configuration: compressor soundproofing (SC)

DAA8S200.2\_210.2\_FCD\_EXC\_SC\_0

Date: 13/05/2015

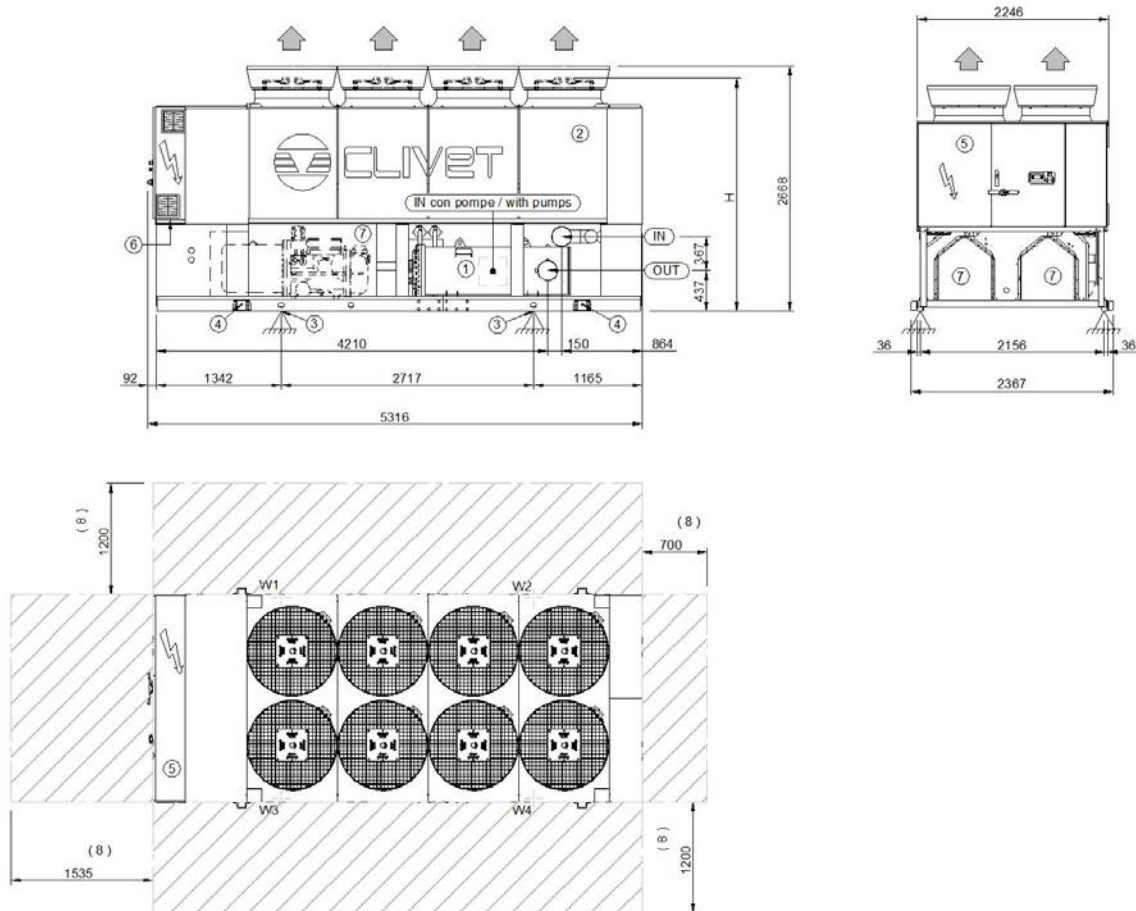

- 1. Internal exchanger (evaporator)
- 2. External exchanger (condenser)
- 3. Unit fixing holes
- 4. Lifting brackets (removable, if required, after the unit positioning)
- 5. Electrical panel
- 6. Power input
- 7. Sound proof enclosure ( only in the relevant versions)
- 8. Clearance access recommended

Size		SC-EXC	
		200.2	210.2
H (without Axitop)	mm	2484	2484
I	mm	-	-
J	mm	-	-
K	mm	-	-
OD (water fittings diameter)		8"	8"
A - Length	mm	5316	5316
B - Depth	mm	2246	2246
C - Height	mm	2668	2668
W1 Supporting point	kg	1637	1649
W2 Supporting point	kg	1387	1394
W3 Supporting point	kg	1664	1673
W4 Supporting point	kg	1414	1418
Shipping weight	kg	5431	5462
Operating weight	kg	6102	6134

The presence of optional accessories may result in a substantial variation of the weights shown in the table. Fan diffusers are separately supplied.

## FCD configuration (Direct FREE-COOLING)

Size 220.2-240.2 - 260.2 - Acoustic configuration: compressor soundproofing (SC)

Size 200.2-210.2 - 220.2 - Acoustic configuration: super-silenced (EN)

DAA8S220.2\_260.2\_FCD\_EXC\_SC\_EN\_0

Date: 13/05/2015

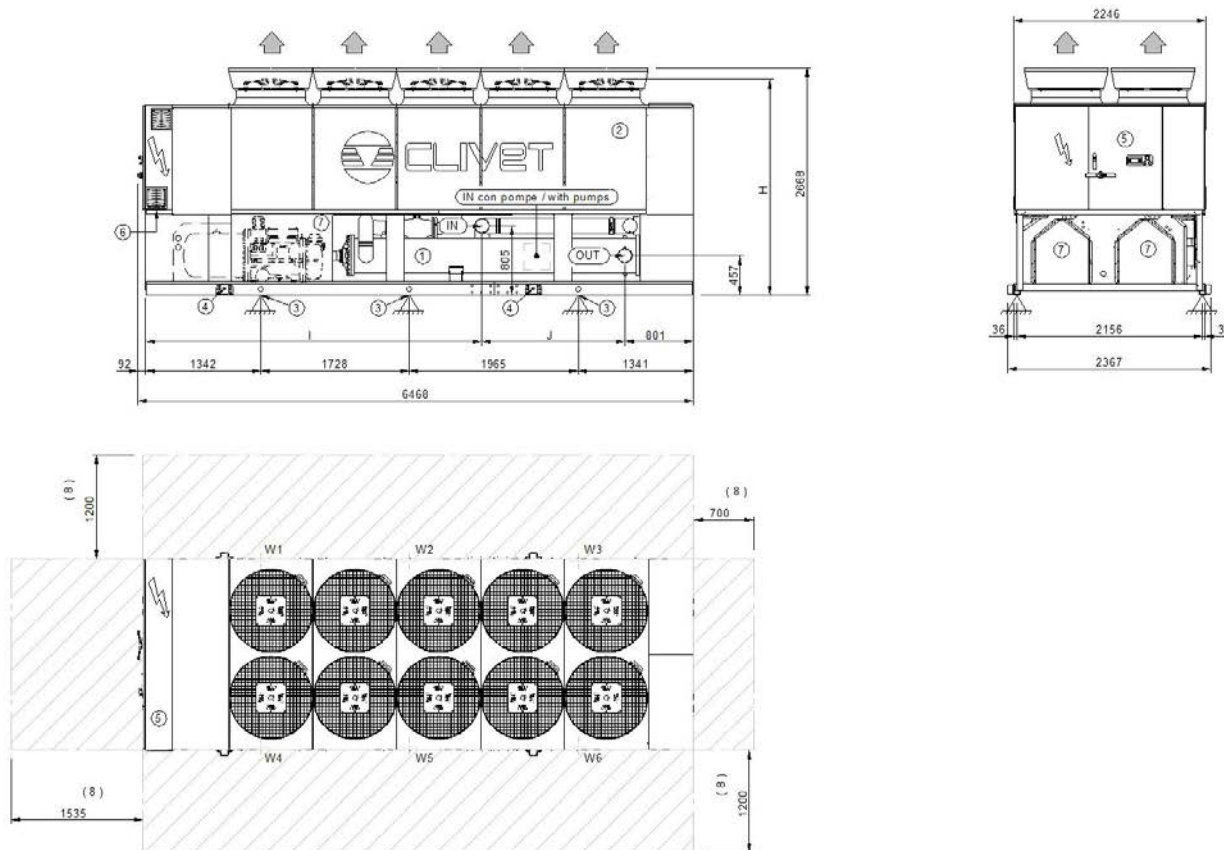

1. Internal exchanger (evaporator)
2. External exchanger (condenser)
3. Unit fixing holes
4. Lifting brackets (removable, if required, after the unit positioning)
5. Electrical panel
6. Power input
7. Sound proof enclosure ( only in the relevant versions)
8. Clearance access recommended

Size		SC-EXC			EN-EXC		
		220.2	240.2	260.2	200.2	210.2	220.2
H (without Axitop)	mm	2484	2484	2484	2510	2510	2510
I	mm	3963	3963	3963	4513	4513	3963
J	mm	1612	1612	1612	1062	1062	1612
K	mm	-	-	-	-	-	-
OD (water fittings diameter)	mm	6"	6"	6"	6"	6"	6"
A - Length	mm	6468	6468	6468	6468	6468	6468
B - Depth	mm	2246	2246	2246	2246	2246	2246
C - Height	mm	2668	2668	2668	2668	2668	2668
W1 Supporting point	kg	1607	1627	1650	1596	1604	1607
W2 Supporting point	kg	1176	1185	1194	1172	1175	1176
W3 Supporting point	kg	882	883	884	885	884	882
W4 Supporting point	kg	1556	1567	1601	1538	1550	1556
W5 Supporting point	kg	1139	1142	1158	1130	1136	1139
W6 Supporting point	kg	854	851	857	853	854	854
Shipping weight	kg	6387	6428	6515	6346	6375	6387
Operating weight	kg	7214	7255	7344	7174	7203	7214

The presence of optional accessories may result in a substantial variation of the weights shown in the table. Fan diffusers are separately supplied.

# FCD configuration (Direct FREE-COOLING)

Size 280.2-320.2 - Acoustic configuration: compressor soundproofing (SC)

Size 240.2-260.2 - Acoustic configuration: super-silenced (EN)

DAA8S280.2\_320 2\_FCD\_EXC\_SC\_EN\_0

Date: 13/05/2015

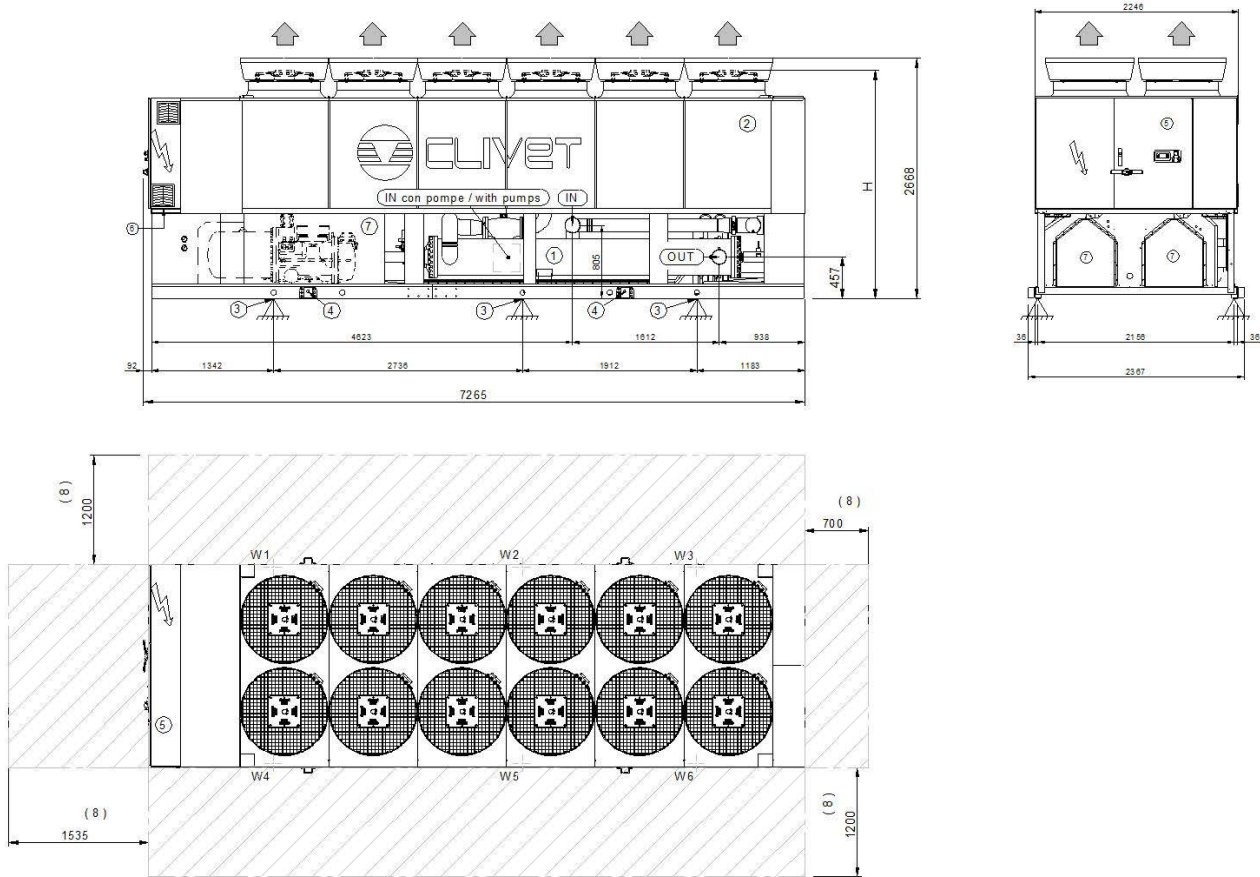

- 1. Internal exchanger (evaporator)
- 2. External exchanger (condenser)
- 3. Unit fixing holes
- 4. Lifting brackets (removable, if required, after the unit positioning)
- 5. Electrical panel
- 6. Power input
- 7. Sound proof enclosure (only in the relevant versions)
- 8. Clearance access recommended

Size		SC-EXC		EN-EXC	
		280.2	320.2	240.2	260.2
H (without Axitop)	mm	2484	2484	2510	2510
I	mm	-	-	-	-
J	mm	-	-	-	-
K	mm	-	-	-	-
OD (water fittings diameter)		6"	6"	6"	6"
A - Length	mm	7265	7265	7265	7265
B - Depth	mm	2246	2246	2246	2246
C - Height	mm	2668	2668	2668	2668
W1 Supporting point	kg	1812	1829	1746	1770
W2 Supporting point	kg	1484	1486	1457	1461
W3 Supporting point	kg	831	828	829	824
W4 Supporting point	kg	1750	1775	1687	1724
W5 Supporting point	kg	1433	1442	1408	1423
W6 Supporting point	kg	802	803	801	803
Shipping weight	kg	7246	7298	7036	7113
Operating weight	kg	8112	8163	7928	8005

The presence of optional accessories may result in a substantial variation of the weights shown in the table. Fan diffusers are separately supplied.

## FCD configuration (Direct FREE-COOLING)

Size 340.2-360.2 - Acoustic configuration: compressor soundproofing (SC)

Size 280.2 - Acoustic configuration: super-silenced (EN)

DAA8S340.2\_360 2\_FCD\_EXC\_SC\_EN\_0

Date: 13/05/2015

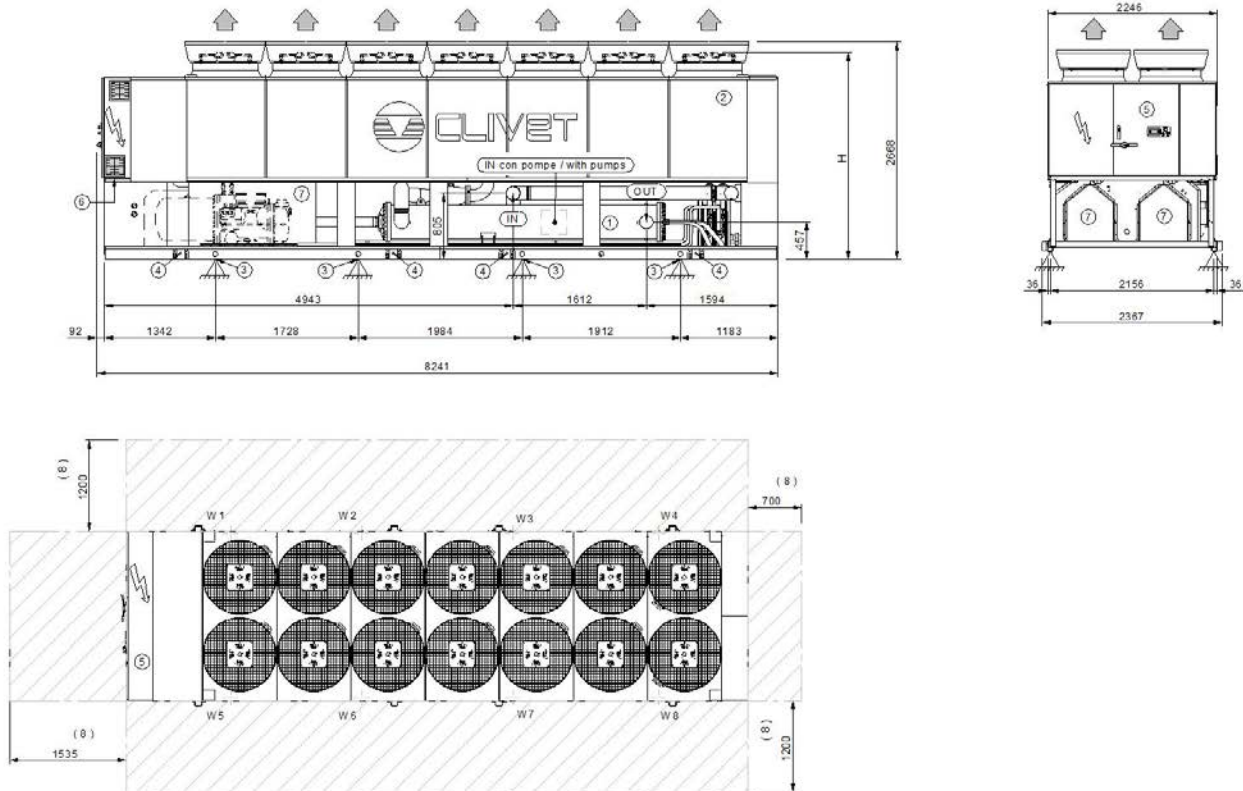

1. Internal exchanger (evaporator)
2. External exchanger (condenser)
3. Unit fixing holes
4. Lifting brackets (removable, if required, after the unit positioning)
5. Electrical panel
6. Power input
7. Sound proof enclosure ( only in the relevant versions)
8. Clearance access recommended

Size		SC-EXC		EN-EXC
		340.2	360.2	280.2
H (without Axitop)	mm	2484	2484	2510
I	mm	-	-	-
J	mm	-	-	-
K	mm	-	-	-
OD (water fittings diameter)		6"	6"	6"
A - Length	mm	8241	8241	8241
B - Depth	mm	2246	2246	2246
C - Height	mm	2668	2668	2668
W1 Supporting point	kg	1639	1805	1614
W2 Supporting point	kg	1163	1247	1153
W3 Supporting point	kg	1063	1067	1074
W4 Supporting point	kg	831	835	842
W5 Supporting point	kg	1581	1736	1559
W6 Supporting point	kg	122	1199	1113
W7 Supporting point	kg	1018	1022	1028
W8 Supporting point	kg	796	799	806
Shipping weight	kg	8262	8759	8239
Operating weight	kg	9213	9710	9189

The presence of optional accessories may result in a substantial variation of the weights shown in the table. Fan diffusers are separately supplied.

# FCD configuration (Direct FREE-COOLING)

Size 400.2-440.2 - Acoustic configuration: compressor soundproofing (SC)

Size 320.2 - 340.2 - 360.2 - Acoustic configuration: super-silenced (EN)

DAA8S400 2\_440 2\_FCD\_EXC\_SC\_EN\_1

Date: 08/06/2015

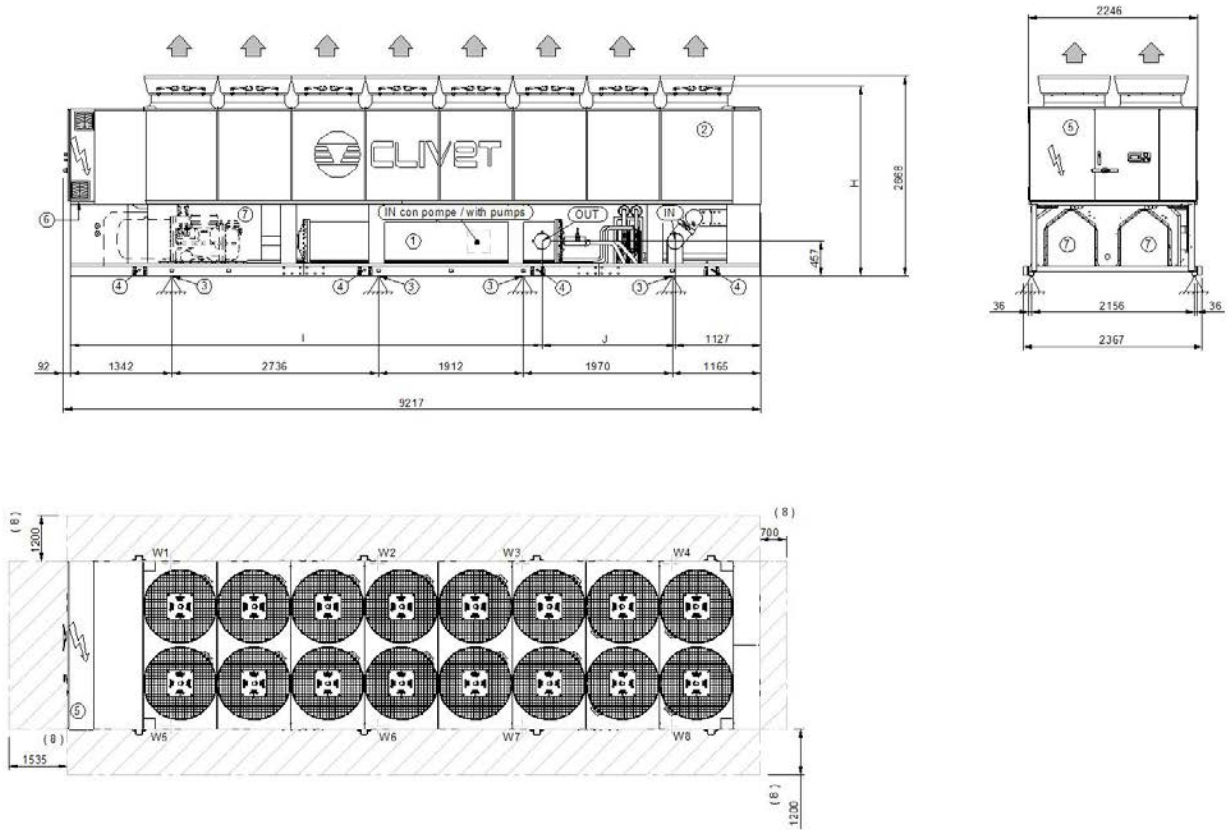

- 1. Internal exchanger (evaporator)
- 2. External exchanger (condenser)
- 3. Unit fixing holes
- 4. Lifting brackets (removable, if required, after the unit positioning)
- 5. Electrical panel
- 6. Power input
- 7. Sound proof enclosure (only in the relevant versions)
- 8. Clearance access recommended

Size		SC-EXC		EN-EXC		
		400.2	440.2	320.2	340.2	360.2
H (without Axitop)	mm	2484	2484	2510	2510	2510
I	mm	6238	6238	6555	6555	6555
J	mm	1760	1760	1443	1443	1443
K	mm	-	-	-	-	-
OD (water fittings diameter)		8"	8"	6"	6"	6"
A - Length	mm	9217	9217	9217	9217	9217
B - Depth	mm	2246	2246	2246	2246	2246
C - Height	mm	2668	2668	2668	2668	2668
W1 Supporting point	kg	2001	2014	1821	1876	1990
W2 Supporting point	kg	1488	1496	1319	1331	1386
W3 Supporting point	kg	1523	1539	1364	1381	1385
W4 Supporting point	kg	753	754	766	765	767
W5 Supporting point	kg	1923	1935	1758	1864	1915
W6 Supporting point	kg	1430	1437	1273	1323	1333
W7 Supporting point	kg	1268	1275	1136	1142	1144
W8 Supporting point	kg	626	624	638	632	634
Shipping weight	kg	9775	9837	9041	9278	9515
Operating weight	kg	11012	11074	10075	10314	10554

The presence of optional accessories may result in a substantial variation of the weights shown in the table. Fan diffusers are separately supplied.



## FCD configuration (Direct FREE-COOLING)

Size 500.2-540.2 - 580.2 - Acoustic configuration: compressor soundproofing (SC)

Size 400.2 - 440.2 - 500.2 - Acoustic configuration: super-silenced (EN)

DAA8S500 2\_580 2\_FCD\_EXC\_SC\_EN\_1

Date: 08/06/2015

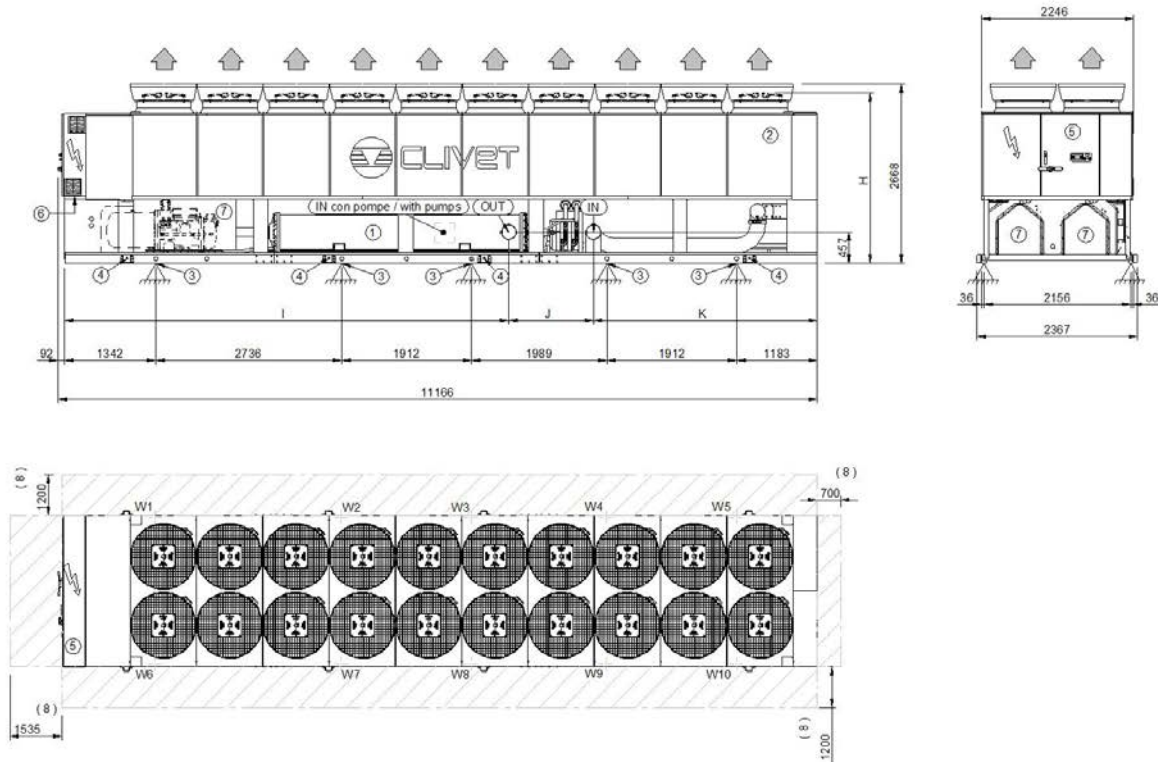

1. Internal exchanger (evaporator)
2. External exchanger (condenser)
3. Unit fixing holes
4. Lifting brackets (removable, if required, after the unit positioning)
5. Electrical panel
6. Power input
7. Sound proof enclosure ( only in the relevant versions)
8. Clearance access recommended

Size		SC-EXC			EN-EXC		
		500.2	540.2	580.2	400.2	440.2	500.2
H (without Axitop)	mm	2484	2484	2484	2510	2510	2510
I	mm	6537	6537	6537	6237	6237	6537
J	mm	1244	1244	1244	1544	1544	1244
K	mm	3293	3293	3293	3293	3293	3293
OD (water fittings diameter)		8"	8"	8"	8"	8"	8"
A - Length	mm	11166	11166	11166	11166	11166	11166
B - Depth	mm	2246	2246	2246	2246	2246	2246
C - Height	mm	2668	2668	2668	2668	2668	2668
W1 Supporting point	kg	2066	2086	2101	2074	2074	2066
W2 Supporting point	kg	1650	1697	1720	1521	1526	1650
W3 Supporting point	kg	980	980	980	802	807	980
W4 Supporting point	kg	809	809	809	877	877	809
W5 Supporting point	kg	728	728	728	799	799	728
W6 Supporting point	kg	1959	1979	1994	1959	1959	1959
W7 Supporting point	kg	1576	1623	1646	1468	1473	1576
W8 Supporting point	kg	932	932	932	753	758	932
W9 Supporting point	kg	721	721	721	792	792	721
W10 Supporting point	kg	614	614	614	685	685	614
Shipping weight	kg	10400	10534	10610	10128	10148	10400
Operating weight	kg	12035	12169	12245	11730	11750	12035

The presence of optional accessories may result in a substantial variation of the weights shown in the table. Fan diffusers are separately supplied.

# FCI configuration (No-glycol FREE-COOLING)

## Size 200.2 - 210.2 - Acoustic configuration: compressor soundproofing (SC)

DAA8S200.2\_210.2\_FCI\_EXC\_SC\_0  
Date: 13/05/2015

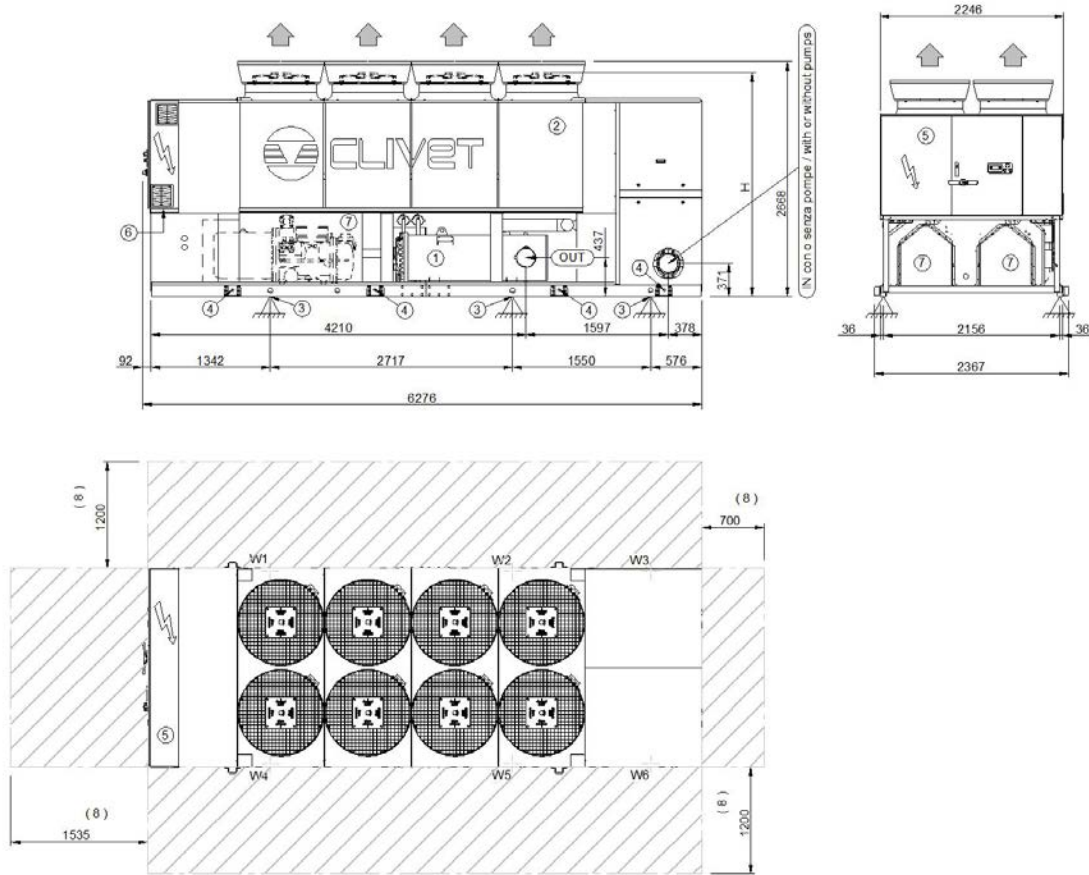

1. Internal exchanger (evaporator)
2. External exchanger (condenser)
3. Unit fixing holes
4. Lifting brackets (removable, if required, after the unit positioning)
5. Electrical panel
6. Power input
7. Sound proof enclosure ( only in the relevant versions)
8. Clearance access recommended

Size		SC-EXC	
		200.2	210.2
H (without Axitop)	mm	2484	2484
I	mm	-	-
J	mm	-	-
K	mm	-	-
L	mm	-	-
OD (water fittings diameter)		8"	8"
A - Length	mm	6276	6276
B - Depth	mm	2246	2246
C - Height	mm	2668	2668
W1 Supporting point	kg	1706	1716
W2 Supporting point	kg	1215	1218
W3 Supporting point	kg	928	926
W4 Supporting point	kg	1648	1662
W5 Supporting point	kg	1173	1180
W6 Supporting point	kg	896	897
Shipping weight	kg	7157	7190
Operating weight	kg	7566	7599

The presence of optional accessories may result in a substantial variation of the weights shown in the table. Fan diffusers are separately supplied.

Shipping weight referred to unit with glycol solution. For the unit weight without glycol solution please refer to the appropriate technical bulletin table.

## FCI configuration (No-glycol FREE-COOLING)

Size 220.2 - 240.2 - 260.2 - Acoustic configuration: compressor soundproofing (SC)

Size 200.2 - 210.2 - 220.2 - Acoustic configuration: super-silenced (EN)

DAA8S220.2\_260.2\_FCI\_EXC\_SC\_EN\_0

Date: 13/05/2015

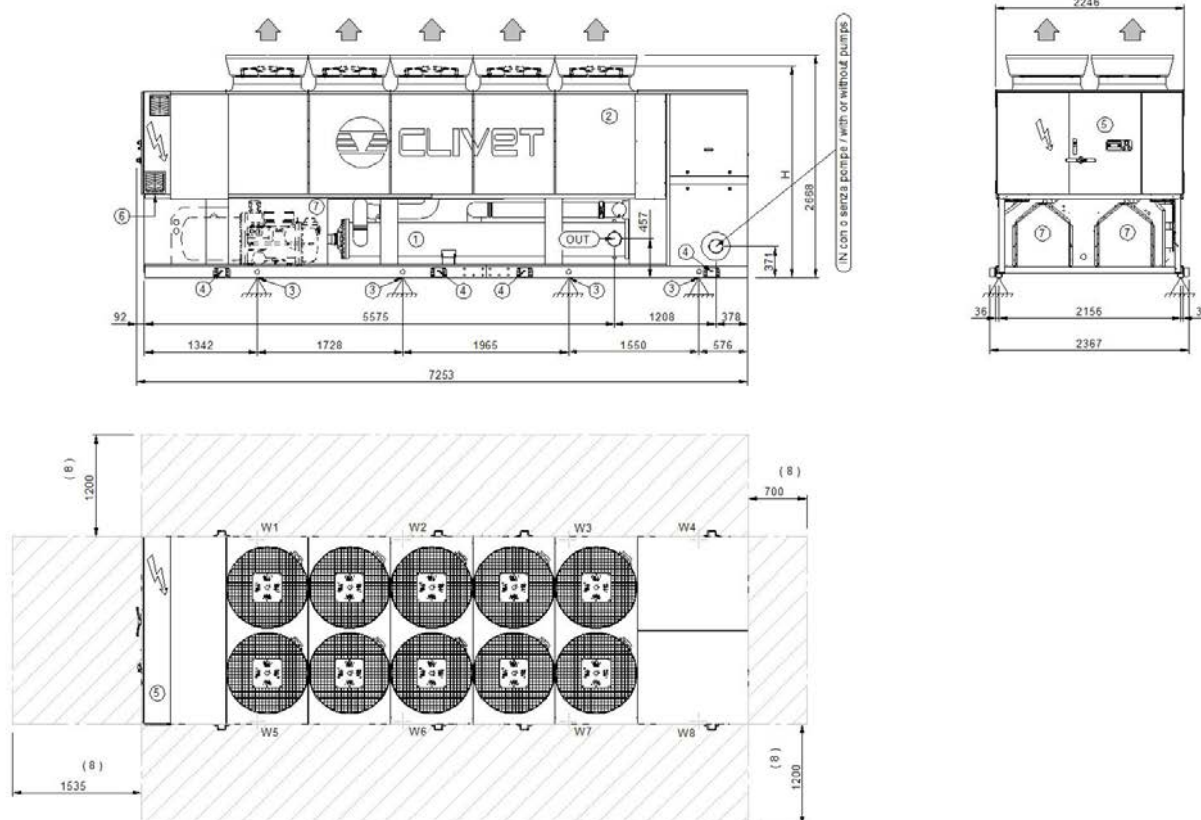

1. Internal exchanger (evaporator)
2. External exchanger (condenser)
3. Unit fixing holes
4. Lifting brackets (removable, if required, after the unit positioning)
5. Electrical panel
6. Power input
7. Sound proof enclosure (only in the relevant versions)
8. Clearance access recommended

Size		SC-EXC			EN-EXC		
		220.2	240.2	260.2	200.2	210.2	220.2
H (without Axitop)	mm	2484	2484	2484	2510	2510	2510
I	mm	-	-	-	-	-	-
J	mm	-	-	-	-	-	-
K	mm	-	-	-	-	-	-
L	mm	-	-	-	-	-	-
OD (water fittings diameter)		6"	6"	6"	6"	6"	6"
A - Length	mm	7253	7253	7253	7253	7253	7253
B - Depth	mm	2246	2246	2246	2246	2246	2246
C - Height	mm	2668	2668	2668	2668	2668	2668
W1 Supporting point	kg	1137	1138	1155	1106	1113	1137
W2 Supporting point	kg	1323	1324	1332	1301	1305	1323
W3 Supporting point	kg	678	678	682	673	675	678
W4 Supporting point	kg	1032	1045	1055	1021	1026	1032
W5 Supporting point	kg	1088	1089	1119	1059	1070	1088
W6 Supporting point	kg	1266	1267	1291	1246	1255	1266
W7 Supporting point	kg	658	658	661	652	655	658
W8 Supporting point	kg	1001	1014	1023	991	995	1001
Shipping weight	kg	7747	7771	7869	7620	7661	7747
Operating weight	kg	8183	8213	8318	8049	8094	8183

The presence of optional accessories may result in a substantial variation of the weights shown in the table. Fan diffusers are separately supplied.

Shipping weight referred to unit with glycol solution. For the unit weight without glycol solution please refer to the appropriate technical bulletin table.

# FCI configuration (No-glycol FREE-COOLING)

Size 280.2 - 320.2 Acoustic configuration: compressor soundproofing (SC)

Size 240.2 - 260.2 Acoustic configuration: super-silenced (EN)

DAA8S280.2\_320 2\_FCI\_EXC\_SC\_EN\_0

Date: 13/05/2015

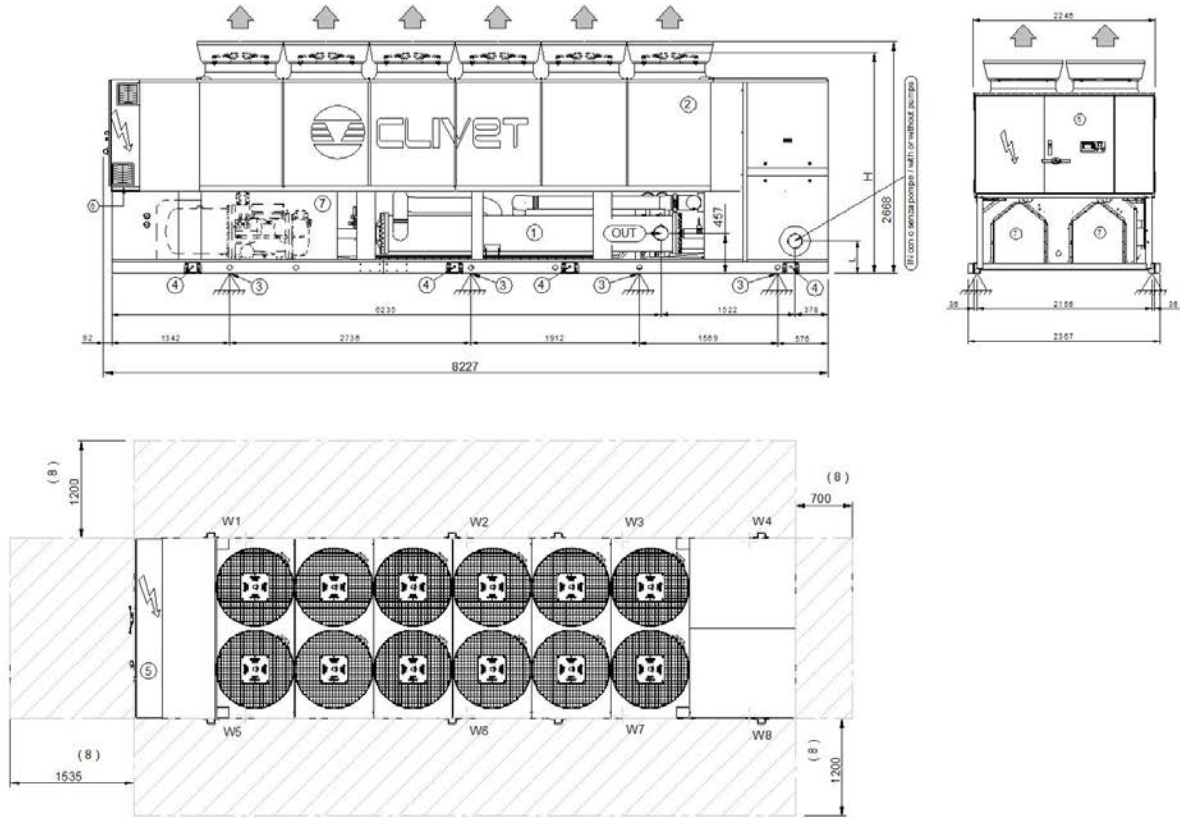

- 1. Internal exchanger (evaporator)
- 2. External exchanger (condenser)
- 3. Unit fixing holes
- 4. Lifting brackets (removable, if required, after the unit positioning)
- 5. Electrical panel
- 6. Power input
- 7. Sound proof enclosure (only in the relevant versions)
- 8. Clearance access recommended

Size		SC-EXC		EN-EXC	
		280.2	320.2	240.2	260.2
H (without Axitop)	mm	2484	2484	2510	2510
I	mm	-	-	-	-
J	mm	-	-	-	-
K	mm	-	-	-	-
L	mm	333	333	371	371
OD (water fittings diameter)	mm	6"	6"	6"	6"
A - Length	mm	8227	8227	8227	8227
B - Depth	mm	2246	2246	2246	2246
C - Height	mm	2668	2668	2668	2668
W1 Supporting point	kg	1695	1701	1635	1645
W2 Supporting point	kg	961	970	928	942
W3 Supporting point	kg	834	835	839	839
W4 Supporting point	kg	1241	1258	1171	1182
W5 Supporting point	kg	1628	1645	1573	1601
W6 Supporting point	kg	923	939	893	917
W7 Supporting point	kg	809	811	814	814
W8 Supporting point	kg	1205	1222	1136	1147
Shipping weight	kg	8826	8906	8520	8613
Operating weight	kg	9296	9381	8989	9087

The presence of optional accessories may result in a substantial variation of the weights shown in the table. Fan diffusers are separately supplied.

Shipping weight referred to unit with glycol solution. For the unit weight without glycol solution please refer to the appropriate technical bulletin table.

# FCI configuration (No-glycol FREE-COOLING)

Size 340.2 - 360.2 Acoustic configuration: compressor soundproofing (SC)

Size 280.2 - Acoustic configuration: super-silenced (EN)

DAA8S340.2\_360.2\_FCI\_EXC\_SC\_EN\_0

Date: 13/05/2015

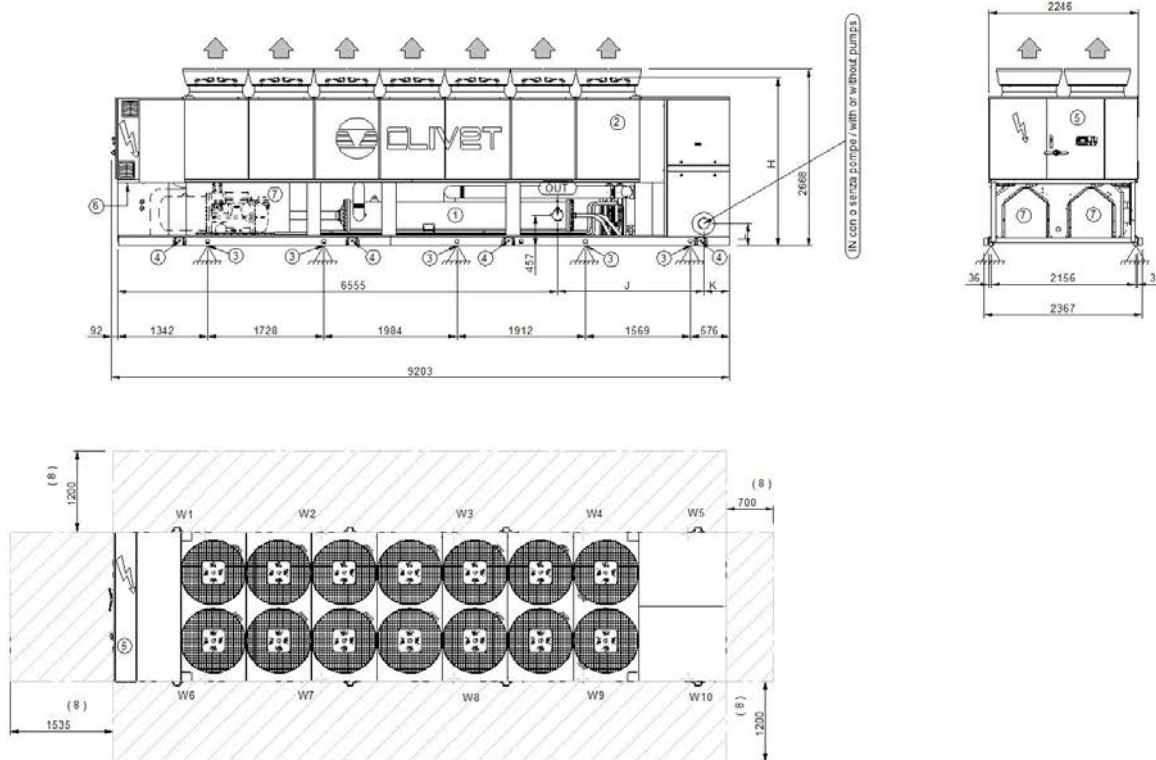

1. Internal exchanger (evaporator)
2. External exchanger (condenser)
3. Unit fixing holes
4. Lifting brackets (removable, if required, after the unit positioning)
5. Electrical panel
6. Power input
7. Sound proof enclosure (only in the relevant versions)
8. Clearance access recommended

Size		SC-EXC		EN-EXC
		340.2	360.2	280.2
H (without Axitop)	mm	2484	2484	2510
I	mm	-	-	-
J	mm	1977	1977	2178
K	mm	579	579	378
L	mm	351	351	333
OD (water fittings diameter)		6"	6"	6"
A - Length	mm	9203	9203	9203
B - Depth	mm	2246	2246	2246
C - Height	mm	2668	2668	2668
W1 Supporting point	kg	2072	2272	2029
W2 Supporting point	kg	545	605	531
W3 Supporting point	kg	1186	1181	1181
W4 Supporting point	kg	609	618	602
W5 Supporting point	kg	1157	1179	1050
W6 Supporting point	kg	2001	2184	1961
W7 Supporting point	kg	524	579	511
W8 Supporting point	kg	1191	1186	1185
W9 Supporting point	kg	607	617	601
W10 Supporting point	kg	1157	1179	1050
Shipping weight	kg	10508	11049	10212
Operating weight	kg	11049	11600	10701

The presence of optional accessories may result in a substantial variation of the weights shown in the table. Fan diffusers are separately supplied.

Shipping weight referred to unit with glycol solution. For the unit weight without glycol solution please refer to the appropriate technical bulletin table.

# FCI configuration (No-glycol FREE-COOLING)

Size 400.2 - 440.2 Acoustic configuration: compressor soundproofing (SC)

Size 320.2 - 340.2 - 360.2 Acoustic configuration: super-silenced (EN)

DAA8S400 2\_440 2\_FCI\_EXC\_SC\_EN\_0

Date: 15/04/2015

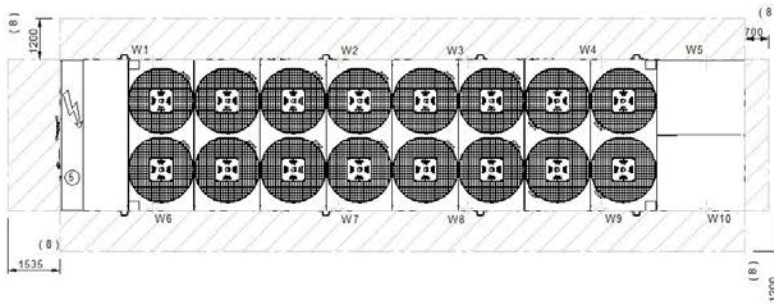
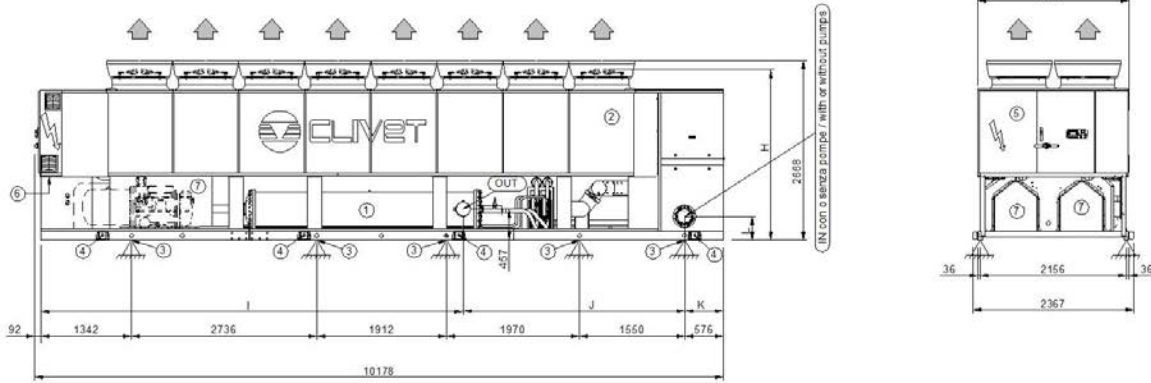

- 1. Internal exchanger (evaporator)
- 2. External exchanger (condenser)
- 3. Unit fixing holes
- 4. Lifting brackets (removable, if required, after the unit positioning)
- 5. Electrical panel
- 6. Power input
- 7. Sound proof enclosure (only in the relevant versions)
- 8. Clearance access recommended

Size		SC-EXC		EN-EXC		
		400.2	440.2	320.2	340.2	360.2
H (without Axitop)	mm	2484	2484	2510	2510	2510
I	mm	6238	6238	6555	6555	6555
J	mm	3269	3269	3154	2952	2952
K	mm	579	579	377	579	579
L	mm	371	371	333	351	351
OD (water fittings diameter)		8"	8"	6"	6"	6"
A - Length	mm	10178	10178	10178	10178	10178
B - Depth	mm	2246	2246	2246	2246	2246
C - Height	mm	2668	2668	2668	2668	2668
W1 Supporting point	kg	2454	2467	2203	2267	2408
W2 Supporting point	kg	1302	1307	1106	1122	1153
W3 Supporting point	kg	1105	1107	945	944	934
W4 Supporting point	kg	614	616	605	609	613
W5 Supporting point	kg	1182	1206	1087	1177	1196
W6 Supporting point	kg	2359	2371	2125	2263	2313
W7 Supporting point	kg	1282	1286	1089	1122	1133
W8 Supporting point	kg	1113	1114	951	945	942
W9 Supporting point	kg	612	614	603	609	611
W10 Supporting point	kg	1183	1206	1087	1177	1196
Shipping weight	kg	12231	12297	11285	11675	11928
Operating weight	kg	13206	13294	11801	12235	12499

The presence of optional accessories may result in a substantial variation of the weights shown in the table. Fan diffusers are separately supplied.

Shipping weight referred to unit with glycol solution. For the unit weight without glycol solution please refer to the appropriate technical bulletin table.

## FCI configuration (No-glycol FREE-COOLING)

Size 500.2 - 540.2 - 580.2 Acoustic configuration: compressor soundproofing (SC)

Size 400.2 - 440.2 - 500.2 Acoustic configuration: super-silenced (EN)

DAA8S500 2\_580 2\_FCI\_EXC\_SC\_EN\_0

Date: 13/04/2015

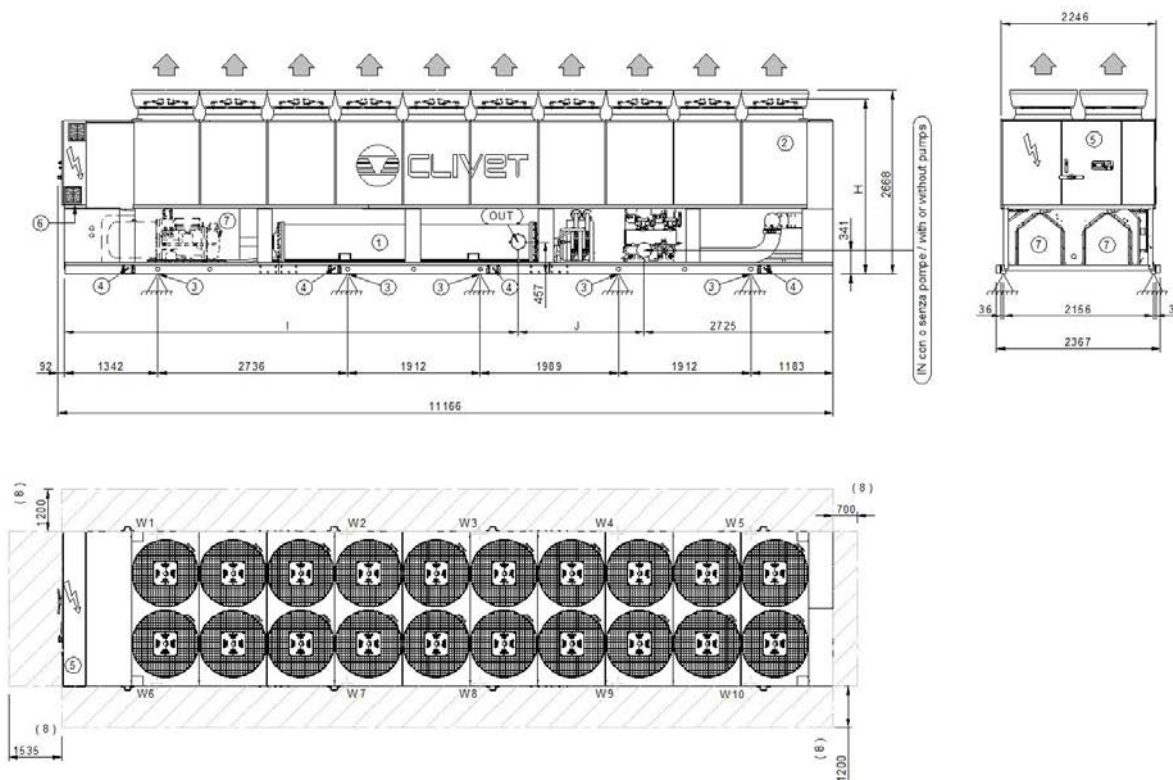

1. Internal exchanger (evaporator)
2. External exchanger (condenser)
3. Unit fixing holes
4. Lifting brackets (removable, if required, after the unit positioning)
5. Electrical panel
6. Power input
7. Sound proof enclosure (only in the relevant versions)
8. Clearance access recommended

Size		SC-EXC			EN-EXC		
		500.2	540.2	580.2	400.2	440.2	500.2
H (without Axitop)	mm	2484	2484	2484	2510	2510	2510
I	mm	6537	6537	6537	6237	6237	6537
J	mm	1812	1812	1812	2112	2112	1812
K	mm	-	-	-	-	-	-
L	mm	-	-	-	-	-	-
OD (water fittings diameter)		8"	8"	8"	8"	8"	8"
A - Length	mm	11166	11166	11166	11166	11166	11166
B - Depth	mm	2246	2246	2246	2246	2246	2246
C - Height	mm	2668	2668	2668	2668	2668	2668
W1 Supporting point	kg	2530	2585	2612	2484	2502	2530
W2 Supporting point	kg	1390	1403	1411	1115	1125	1390
W3 Supporting point	kg	1089	1084	1079	1272	1275	1089
W4 Supporting point	kg	947	968	993	894	920	947
W5 Supporting point	kg	1220	1226	1231	1196	1208	1220
W6 Supporting point	kg	2431	2481	2506	2389	2406	2431
W7 Supporting point	kg	1369	1382	1389	1095	1105	1369
W8 Supporting point	kg	1097	1092	1088	1280	1282	1097
W9 Supporting point	kg	945	966	991	893	918	945
W10 Supporting point	kg	1220	1226	1232	1196	1208	1220
Shipping weight	kg	13353	13519	13627	12993	13117	13353
Operating weight	kg	14238	14413	14532	13814	13949	14238

The presence of optional accessories may result in a substantial variation of the weights shown in the table. Fan diffusers are separately supplied.

Shipping weight referred to unit with glycol solution. For the unit weight without glycol solution please refer to the appropriate technical bulletin table.



**CLIVET SPA**

Via Camp Lonc 25, Z.I. Villapaiera - 32032 Feltre (BL) - Italy  
Tel. + 39 0439 3131 - Fax + 39 0439 313300 - info@clivet.it

**CLIVET GROUP UK Limited**

4 Kingdom Close, Segensworth East - Fareham, Hampshire - PO15 5TJ - United Kingdom  
Tel. + 44 (0) 1489 572238 - Fax + 44 (0) 1489 573033 - enquiries@clivetgroup.co.uk

**CLIVET GROUP UK Limited (Operations)**

Units F5&F6 Railway Triangle Ind Est, Walton Road - Portsmouth, Hampshire - PO6 1TG - United Kingdom  
Tel. +44 (0) 2392 381235 - Fax. +44 (0) 2392 381243 - service@clivetgroup.co.uk

**CLIVET ESPAÑA S.A.U.**

C/ Bac de Roda, 36 - 08019 Barcelona - España  
Tel: +34 93 8606248 - Fax +34 93 8855392 - info@clivet.es

Av.Manoterás Nº 38, Oficina C303 - 28050 Madrid - España  
Tel. +34 91 6658280 - Fax +34 91 6657806 - info@clivet.es

**CLIVET GmbH**

Hummelsbütteler Steindamm 84, 22851 Norderstedt - Germany  
Tel. + 49 (0) 40 32 59 57-0 - Fax + 49 (0) 40 32 59 57-194 - info.de@clivet.com

**CLIVET RUSSIA**

Elektrozavodskaya st. 24, office 509 - 107023, Moscow, Russia  
Tel. + 74956462009 - Fax + 74956462009 - info.ru@clivet.com

**CLIVET MIDEAST FZCO**

Dubai Silicon Oasis (DSO), High Bay Complex, Office N. 20, PO BOX 342009, Dubai, UAE  
Tel. + 9714 3208499 - Fax + 9714 3208216 - info@clivet.ae

**CLIVET AIRCONDITIONING SYSTEMS PRIVATE LIMITED**

4BA, Gundecha Onclave, Kherani Road - Sakinaka, Andheri (East) - Mumbai 400 072 - India  
Tel. +91 22 6193 7000 - Fax +91 22 6193 7001 - info.in@clivet.com

[www.clivet.com](http://www.clivet.com)  
[www.clivetlive.com](http://www.clivetlive.com)

A Group Company of

